



EGS Electrical Connection Product Catalog

EGS Electrical Connection

Product Catalog

About

Curtiss-Wright Nuclear supplies safety-related and environmentally qualified electrical interconnection products, known under the brand name EGS. Manufactured in the United States at the Huntsville, Alabama facilities, all EGS brand products are qualified by test for the harshest conditions, inside and outside containment areas, in PWR, BWR, and CANDU reactors. EGS is comprised of a broad range of products, from Class-1E single conductor splices up to containment electrical penetration assemblies, and has become internationally known as a world leader in the supply of safety-related connection devices.

EGS brand products are designed, manufactured, qualified, and supplied in accordance with ANSI N45.2, 10CFR50 Appendix B, and 10CFR21.

Table of Contents

Electrical Penetration Assembly (EPA)	1
EGS Quick Disconnect Connector (QDC)	3
EGS QDC Generation 3	5
EGS Hard Line Connector	7
EGS Temperature Switch	9
Specialty Cable Assembly	11
EGS Hi/Lo Pressure Seal	12
EGS Conduit Seal	13
EGS Electrical Conduit Seal Assembly (ECSA)	15
EGS BLUEBOOT Connector Series	17
EGS BLUEBOOT Selection Guide	19
EGS GRAYBOOT Connector Series	21
EGS GRAYBOOT Selection Guide	23
EGS GRAYBOOT Rack	24
EGS GRAYBOOT "A" Connector Series	25
EGS GRAYBOOT "A" Selection Guide	27
EGS Flexible Metal Conduit	29
BWR/PWR Compact Splice	31
CANDU Compact Splice	33
Electrical Splicing Tape	35
EGS Splice Rack	37
EGS Thread Sealant (P-1)	38
Conformal Coating (PECC)	39



Nuclear Power Products and Services

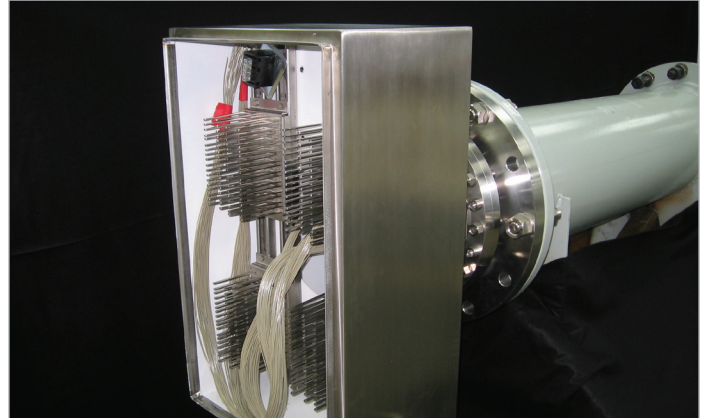
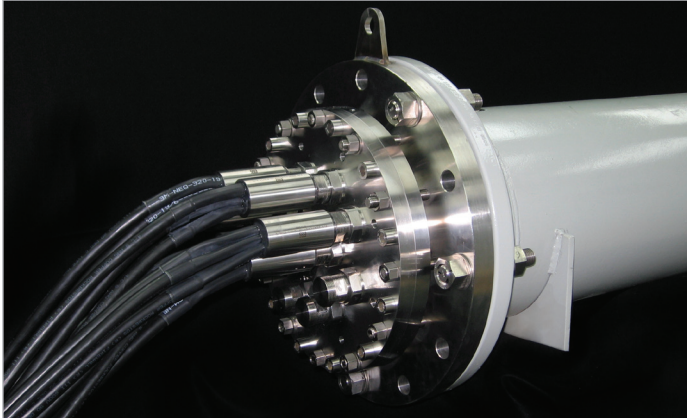

Product Description

Electrical Penetration Assemblies (EPAs) transfer electrical power and signals through the NPP containment wall and ensure the containment pressure boundary is maintained during design basis accident conditions. This dual function, as a safety-related electrical and mechanical device, makes the EPA a unique nuclear component.

EPAs are configured with individual feedthrough modules that are mounted to a bulkhead flange, header plate, or canister. Feedthrough modules are constructed with electrical conductors to pass electrical signals or power, insulators, and seals in a stainless steel housing. Feedthrough modules and the bulkhead flange aperture are supplied with double redundant seals and internal nitrogen gas containment space for leakage monitoring.

Application Design Options

- Low voltage power
- Control and instrumentation
- Coaxial and triaxial instrumentation
- Medium voltage power
- Fiber optic

Available Configurations

- Bulkhead flange (header plate) with removable feedthrough modules
- Canister design with removable or fixed feedthrough modules
- Double bulkhead flanges with feedthrough modules

Penetration pipe size (inches)	Module diameters (inches)	Typical Conductor Range	Typical Wire Insulation Type
4 - 24	1, 1.25, 1.5, or 2	18 AWG to 1500 MCM	PEEK or XLPE

Design Features

The Curtiss-Wright EPA can be supplied with an entire assembly, including:

- Feedthrough modules with integral lead wires
- Flanges, canisters, or header plates
- Junction Boxes (both inboard and outboard)
- N2 pressure gauge and shut off valve

Qualification Levels

- Qualified life: 60 years
- Thermal Aging
- Radiation
- Seismic
- Thermal Cycling
- High Current Testing
- LOCA/MSLB
- Flooding and Severe Accident

Qualification Standards

Successfully qualified by test for applications in harsh PWR/BWR environments, in accordance with:

- ASME NPT Certification
- IEEE 317-1983/2013
- IEEE 323-1974/1983/2003
- IEEE 344-1975/1987/2004
- KBE EP-146
- KBE EP-154
- Equivalent to RCC-E, K1
- 10CFR50/Appendix B
- 10CFR21
- NQA-1
- ISO 9001

EGS Electrical Penetration Assembly

Value Added Appurtenances

The EGS Electrical Penetration Assembly (EPA) can be utilized in conjunction with other industry recognized electrical connection devices to mate to existing plant wiring for ease of installation. We offer integrated electrical enclosures featuring tailored mounting racks for splice applications, including heat shrink or other splices, and GRAYBOOT series reusable splices.

Feedthrough modules can be provided with factory installed GRAYBOOTS to reduce installation costs/time. Curtiss-Wright Nuclear Division can also supply safety-related flexible metal conduit for cable protection and other connector options.

EPA Designs

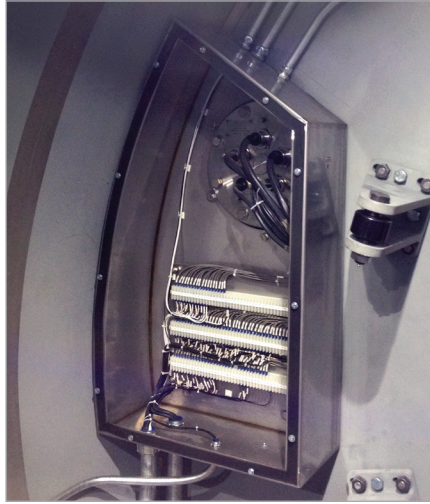

Airlock EPA

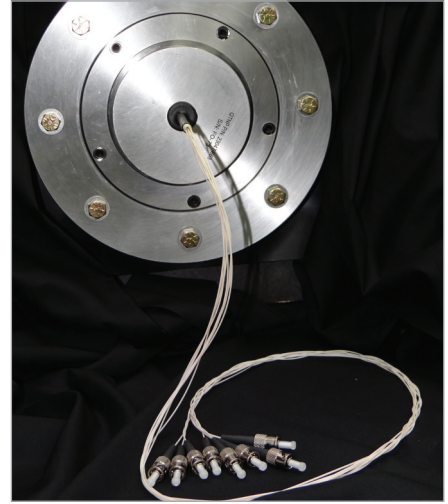

Fiber Optic EPA



GRAYBOOT Splice Series



Coaxial EPA



Triaxial EPA

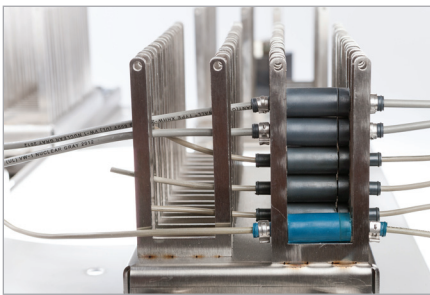

Splice Mounting Rack



Low Voltage EPA



Low Voltage EPA



Flexible Metal Conduit

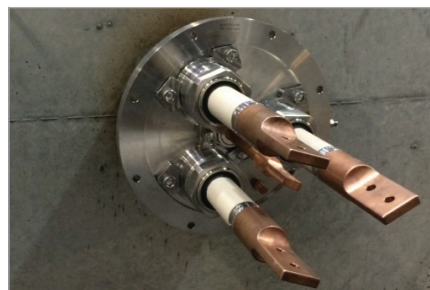

Medium Voltage EPA

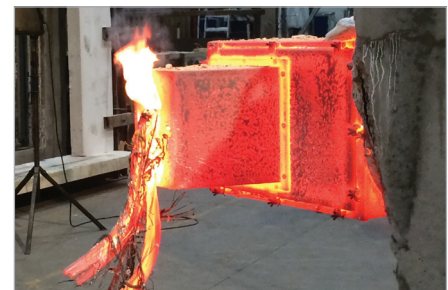

Medium Voltage EPA during fire test

CONTACT INFORMATION:

18001 Sheldon Road, Middleburg Hts., OH 44130
 electricalconnections@curtisswright.com | +1.216.267.3200

EGS Quick Disconnect Connector

3/8", 1/2", 3/4", and 1-1/2"

**CURTISS -
WRIGHT**

Nuclear Power Products and Services



Product Description

Bayonet Style

A true quick-disconnect device that can be locked and unlocked by a simple twist of the hand. The bayonet style features a visual locking indicator for ease of verification.

Hex Nut Style

An optional style designed especially for use in extreme temperature environments since it can use a metal O-ring.

(The 3/8" quick disconnect is only available in the Bayonet Style).

Design Features

- Easy installation/assembly
- Multi-conductor capability
- Small and lightweight
- No special tools or pre-assembly required
- No maintenance, except for periodic O-ring replacement
- Easy interface with device and conduit
- Used on variety of devices such as solenoid valves, transmitters, RTDs, TCs, pressure/limit/level/position switches, MOVs, motors, etc.
- Compatible with ALARA considerations
- Direct replacement for the Rosemount 353C conduit seal

Qualification Reports

- 3/8" QDC Qual: EGS-TR-23062-04
- 1/2" QDC Qual: PEI-TR-880701-04
- 3/4" QDC Qual: EGS-TR-913601-01
- 1-1/2" QDC Qual: EGS-TR-913602-01
- Seismic Supplement: EGS-TR-880706-05
- Supplemental Seismic Report: EGS-TR-880706-14

Qualification Levels

- Qualified life: 40 years at 150°F (62.6°C)
- Radiation: tested to 2.5E8 rads gamma
- Vibration Aging: 0.75g, 90 minutes per axis
- Resonance Frequency: >200 Hz
- Seismic: tested to 8.3g ZPA (SSE)
- Supplemental Seismic: 20g per static load
- Thermal Cycling: 40 cycles at $\Delta T=55^\circ F$
- Accident Peaks: 435°F (223°C), 77psig (632.2 kPa), chemical spray, 100% RH
- Post-accident Aging: equivalent to 1 year at 200°F (93°C)

Qualification Standards

Successfully qualified by test in accordance with:

- 10CFR50.49
- IEEE 572-1985
- IEEE 323-1974/1983
- IEEE 344-1987
- IEEE 382-1980
- ANSI N45.2
- 10CFR50/Appendix B
- CSA Registered

EGS Quick Disconnect Connector

3/8", 1/2", 3/4", and 1-1/2"

Installation (See diagram to right)

Installation is simple. The connector is designed for quick, cost-effective installation into instruments, junction boxes or conduit runs. The connector can be installed using existing device lead wire or integral connector lead wire. Detailed instructions are presented in:

- EGS-TR-880706-01* (Bayonet)
- EGS-TR-880706-02* (Hex)
- EGS-TR-23062-06* (3/8" QDC)

*Latest Revision Applies

Note: Bayonet style is depicted to the right. Hex Nut style is similar with Hex Nut in lieu of Bayonet ring/spring.

1. Pin backshell
2. Socket backshell
3. Bayonet ring
4. Insulator
5. Insulator
6. Insulator
7. Pin
8. Socket
9. Spring
10. O-ring
11. Lead wire/cable
12. Strain relief
13. Potting
14. Set screw
15. Set screw sealant
16. Set Screw

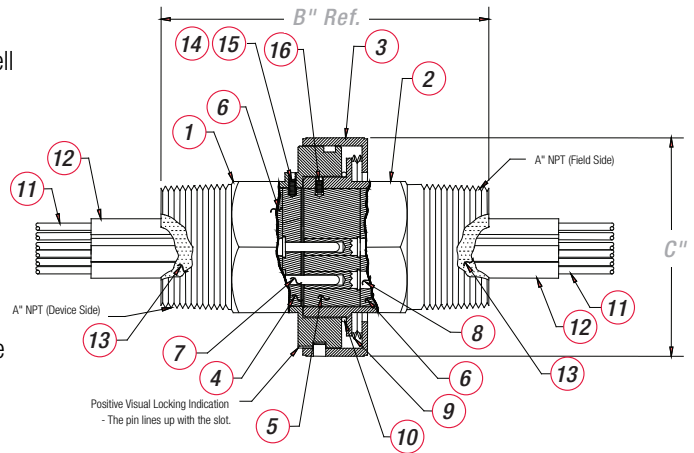

Critical Dimensions

A (inches)	B (inches)	C (Bayonet) (inches)	C (Hex) (inches)	Wt. (lb) without Pigtails
3/8 NPT	3.8	1.3	N/A	0.5
1/2 NPT	4.2	1.6	1.6	0.6
3/4 NPT	4.3	2.2	2.6	1.1
1-1/2 NPT	4.9	3.3	3.4	3.0

Maximum Contact Configurations

(See diagram to right)

Notes: The illustrations shown represent the maximum number of contacts available for the specific wire size shown. Sizes and quantities may increase or decrease based on wire/contact gauge or QDC size utilized.

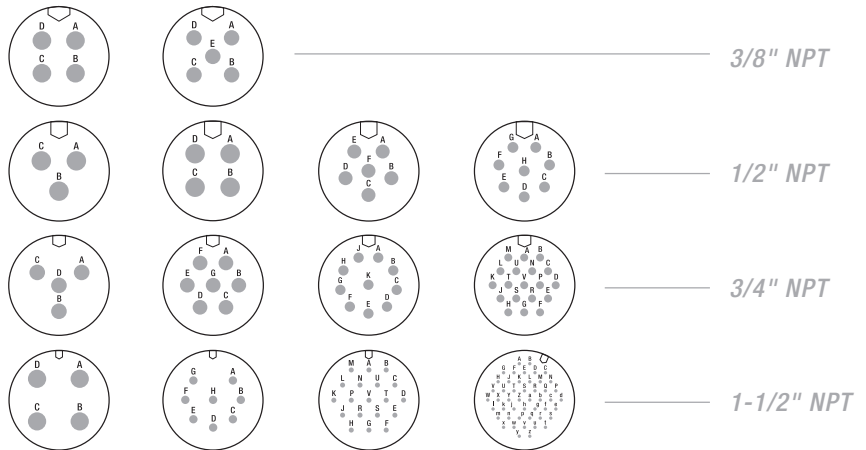

Electrical		20 AWG	16-18 AWG	12-14 AWG	10 AWG	8-10 AWG	4-6 AWG
Maximum Pin Availability	3/8" NPT	5	4	N/A	N/A	N/A	N/A
	1/2" NPT	8	6	4	3	N/A	N/A
	3/4" NPT	19	10	7	4	N/A	N/A
	1-1/2" NPT	N/A	48	19	N/A	8	4
Rated Voltage (volts)		300	600	600	600	600	600
Rated Current (amps) at 90°C		7.5	13	23	23	46	80
Rated Contact Resistance (ohms)		0.008	0.004	0.002	0.002	0.001	0.001

CONTACT INFORMATION:

18001 Sheldon Road, Middleburg Hts., OH 44130
 electricalconnections@curtisswright.com | +1.216.267.3200

EGS Quick Disconnect Connector

Generation 3

**CURTISS -
WRIGHT**

Nuclear Power Products and Services



Product Description

The EGS Generation 3 Quick Disconnect Connector (QDC) is an improved version of the current QDC (Generation 1). The Generation 3 QDC has increased total integrated radiation dose, applied thermal aging for greater than 1,000 hours, attained higher LOCA temperature/pressure, attained greater MSLB temperature and included submergence during LOCA design basis accidents.

Design Features

The Generation 3 QDC is the same as the original QDC (Generation 1 QDC) except for the following design changes:

- Elastomer seals have been installed in the QDC backshell to enhance the sealing capabilities of the potting seal.
- The wave spring force has been reduced to allow easier closure and opening of the bayonet ring.
- The wire/cable strain relief on the QDC socket side (field side or plug side) has been enhanced to provide a more robust strain relief.
- The setscrew material has been changed from alloy steel to stainless steel and the sealant is epoxy.
- A two-piece housing, connector head and backshell, has been added to allow alternate backshell configurations and provide flexibility in matching installation geometries.
- Epoxy Types 7 and 8 provide sealants with higher temperature ratings.
- PEEK insulators provide improved resistance to temperature and radiation effects.

Generation 3 QDCs are intermateable with the original Generation 1 QDC, except for the following:

- 1/2" QDC with 12 AWG pins will not intermate.

Gen. 3 QDC Enhancements

Inner Seal

The inner seal is a redundant seal supplied for enhanced hermeticity that is an optional back-up for the standard coupling O-ring. A special socket-side housing must be used in conjunction with the inner seal, i.e. it cannot be used with standard Gen 3 QDC socket-side assemblies.

360 degree EMI Shield and Double Shielded Cable

A 360° EMI Shield and Double Shielded cable is available as an option to improve resistance to EMI/RFI effects. Consult factory for specific configurations available.

Welded QDC Pin Side Housing

Gen 3 QDC pin-sides may be supplied with a welded backshell as an alternative to the standard NPT threads. Consult factory to discuss the specifics of the welded backshell design with respect to the particular host equipment.

EGS Quick Disconnect Connector

Generation 3

Qualification Levels *(Chronologically listed by test sequence)*

- Vibration Aging: .025" double amplitude, <0.75g, 5-200-5 Hz
- Thermal Cycling: 10 cycles, 30°C-121°C-30°C
- Cycle Aging: 160 connection cycles (not a limit)
- Thermal Aging: 1227.55 hours at 126.6°C, QL = 60 years at 144°F (62.22°C)
- Normal Radiation: 3.15E7 rads-air (315 KGy-air) gamma
- Thermal Cycling: 10 cycles, 30°C-121°C-30°C
- Seismic Qualification:
 - RIM Sine Sweep OBE: 10g, 2-100-2 Hz;
 - RIM Sine Beat SSE: >10g, 2-64 Hz
 - RMF Triaxial SSE: ZPA = 7g

Design Basis Accident and Submergence Levels

- LOCA Radiation: 2.0E8 rads-air (2.0 MGy-air);
TID = 3.15E7 + 2.0E8 = 2.315E8 rads-air (2.315 MGy-air)
- Containment Integrity Test: 24 hours at 68 psig (570.2 kPa)
- LOCA Accident:
 - (Specimens 1, 3, 5, 7): Peak = 495°F/108 psia (257.22°C/675.7 kPa), 4-day chemical spray, 31 day duration
 - (Specimens 2, 8): Peak = 498°F/98 psia (258.89°C/675.7 kPa), 24-hour chemical spray, 32 day duration
- Submergence:
 - (Specimens 1, 7): 284°F/74.5 psia (140°C/513.7 kPa), 30 days in chemical spray fluid. Submergence time may be extrapolated to up to 1 year
 - (Specimen 8): 285°F/62 psia (140.56°C/427.5 kPa), 31 days in chemical spray fluid. Submergence time may be extrapolated to up to 1 year
- MSLB Accident:
 - (Specimens 4, 6): Peak = 491°F/109 psia (255°C/751.5 kPa), 24 hour duration
- MSIV Accident:
 - (Specimens 2, 8): Peak = 525°F/98 psia (273.89°C/675.7 kPa), 27.5 hour duration

Qualification Standards

Successfully qualified by test in accordance with:

- 10CFR50.49
- IEEE 572-1985
- IEEE 323-1974/1983
- IEEE 344-1987
- IEEE 382-1980
- ANSI N45.2
- 10CFR50/Appendix B
- CSA Registered

CONTACT INFORMATION:

18001 Sheldon Road, Middleburg Hts., OH 44130
electricalconnections@curtisswright.com | +1.216.267.3200

EGS Hard Line Connector



Nuclear Power Products and Services



Product Description

The EGS Hard Line Connector (HLC) is a two connector, screw together, quick disconnect sealed connector whose performance in accident conditions is equivalent to an uninterrupted, nuclear grade, mineral insulated (MI) cable or other existing connectors for core exit thermocouples. Unlike other connectors of similar type, it may be installed by plant personnel with minimal training. This connector has a stainless steel body and a unique design feature with which the user's field wiring is simply pushed into the contacts, requiring no crimping.

Installation training classes are available.

Design Features

- Quick connect/disconnect (push/pull)
- Easy installation
- Utilizes existing MI cable
- Push-in contacts (no crimping)
- Low maintenance
- Rugged construction
- Equivalent performance to high cost connectors
- Installation kits available
- Temperature rating 125°C (257°F)

Qualification Levels

- Qualified life 33.58 years at 170°F (76.67°C)
- Radiation: 2.707E7 rads gamma
- Seismically tested to 15g peak and 6.0g ZPA
- LOCA: tested to 361°F (182.78°C) and 149 psig (1128.7 kPa)
- LOCA Radiation: 1.550E8 rads gamma
- Chemical spray solution for 24 hrs at 250°F (121.11°C) SAT
- Supplied under EGS Nuclear QA Program in accordance with ANSI N45.2, 10CFR50/Appendix B, 10CFR21 and NQA-1

Qualification Levels

(Per EGS Report EGS-TR-23020-04)

- Qualified Life: 33.58 years at 170°F (76.67°C)
 - Radiation: 1.82E8 rads gamma
 - Seismic: 15 g peak and 6.0 g's ZPA
 - Accident Peaks: 361°F/149 psig (182.78°C/1,128.7 kPa)
- (See graph below)*

Qualification Standards

Successfully qualified by test in accordance with:

- IEEE 323-1974/1983
- IEEE 344-1975/1987
- IEEE 572-1985
- 10CFR50.49

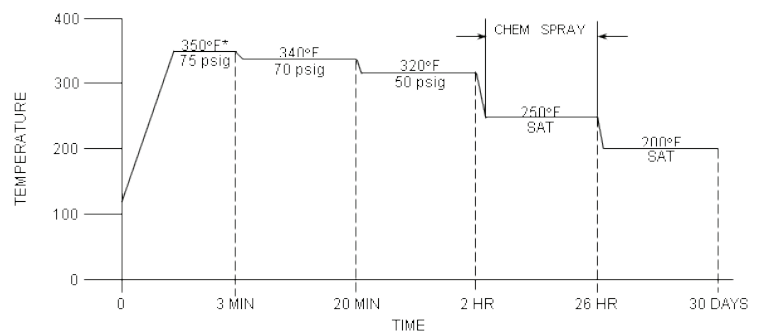

EGS Hard Line Connector

Installation

Installation is quick and easy. The MI cable wire ends (11) are stripped then the end caps (1), ferrules (2), and potting adapters (3) are slipped over the MI cable. The coupling ring (8) is slipped over the pin backshell (7) and environmental seal (9) installed. The MI cable wire is pushed into the contacts (5) on both the socket and pin backshells. The potting adapters, ferrules and end caps are assembled onto the backshells. The connector is potted on both sides, the heat shrink (10) slipped on and coupling ring engaged. The final step is to apply the heat shrink over the connector and coupling ring.

Item	Description	Material
1	End Cap	Stainless Steel 300 Series
2	Ferrule	PEI
3	Potting Adapter	Stainless Steel 300 Series
4	Potting	Epoxy
5	Contacts	Alumel or Chromel
6	Socket Backshell	Stainless Steel 300 Series
7	Pin Backshell	Stainless Steel 300 Series
8	Coupling Ring	Stainless Steel 300 Series
9	Environmental Seal	EPDM
10	Heat Shrink	XLPO
11	MI Cable	Stainless Steel Sheath
12	Nut	Stainless Steel 300 Series
13	Lock Washer	Stainless Steel 300 Series

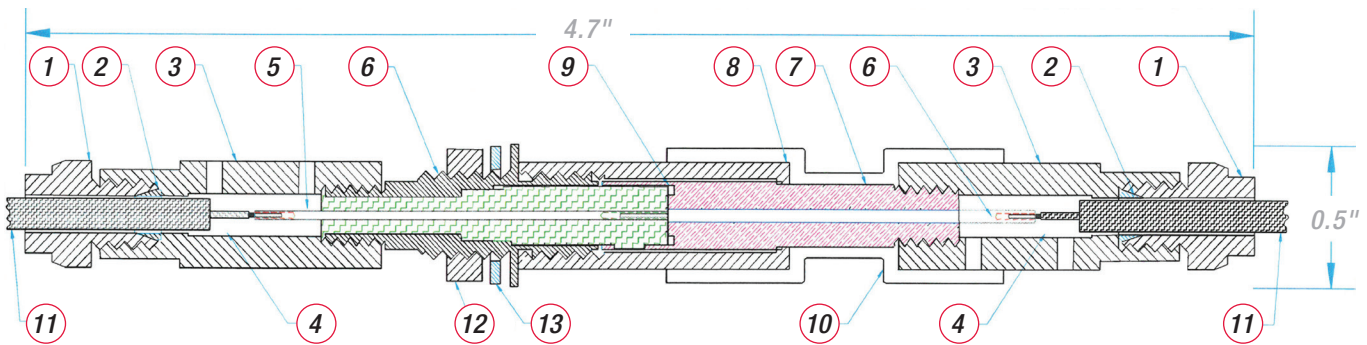

How to Order

The EGS HLC is ordered by P/N and conductor size per the following:

- A. Connector Designation
- B. Number of Conductors
- C. Socket Side Conductor Size
- D. Pin Side Conductor Size
- E. Thermocouple Type
- F. Diameter of Socket Side Cable
- G. Diameter of Pin Side Cable
- H. If used:
 - PM - Panel Mount
 - S - Socket Side
 - P - Pin Side

Example: 23020 - 2 - 24 - 26 - K - 125 - 083 - PM

A
B
C
D
E
F
G
H

P/N	Description
23020-2-24-26-K-125-083	In-Line HLC Connector Kit
23020-2-26-26-K-083-083-PM	Panel Mount HLC Connector Kit
23020-2-24-K-125-S	In-Line HLC Socket Side Only Connector Kit
23020-2-26-K-083-P	In-Line or Panel Mount HLC Pin Side Only Connector Kit
23020-2-26-K-083-S-PM	Panel Mount HLC Socket Side Only Connector Kit

Notes:

- Individual components such as environmental seals can be ordered per part numbers shown on HLC Assembly Drawings B-N-23020-11, -12, -17, -18 or -19.
- P/Ns can be provided to meet various customer requirements such as different thermocouple types or MI cable diameters.

CONTACT INFORMATION:

18001 Sheldon Road, Middleburg Hts., OH 44130
 electricalconnections@curtisswright.com | +1.216.267.3200

EGS Temperature Switch

**CURTISS -
WRIGHT**

Nuclear Power Products and Services

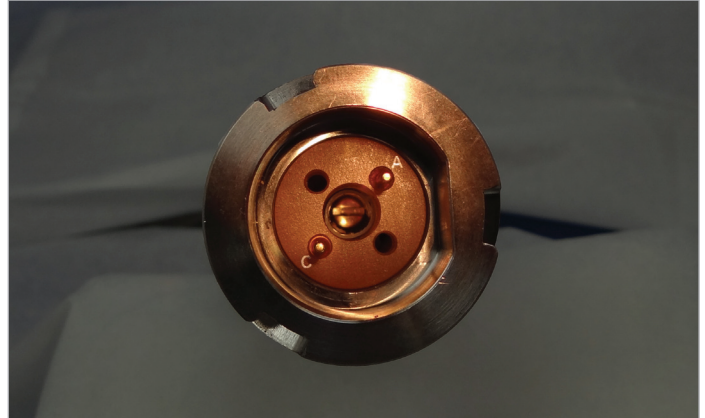

Product Description

The EGS Temperature Switch units are strut-and-tube type thermostiches comprised of two basic parts:

1. the outer shell made of a high expanding metal, and
2. the strut assembly made of low-expanding metal.

A pair of electrical contacts are mounted on the strut assembly and installed in the shell under tension or compression. Each end of the strut assembly is mechanically connected to the ends of the shell. A net change in force is produced on the low-expansion strut assembly as the high-expanding shell expands or contracts with changing temperature. The contact "make" or "break" temperature can be regulated by a temperature adjusting screw. This electromechanical switch comes with integral Quick Disconnect Connector (QDC) for easy installation/removal.

Design Features

- Electrical ratings:
 - 10A at 120 VAC
 - 5A at 240 VAC
 - 2A at 120 VDC
- Adjustable temperature range from -100°F to 600°F (-73°C to 316°C)
- Available in normally open (N.O.) or normally closed (N.C.) configurations
- Switches close on temperature rise or open on temperature rise
- 20' field cable on socket side (standard)
- Electrical components hermetically sealed by disconnect assembly
- Mounting base available
- Direct replacement temperature switches for Models 17002-40 and 17023-6 (previously supplied by Fenwal, Inc.) and EGS models 01-170020-090 (N.C.) and 01-170230-090 (N.O.).
- Accuracy: Setpoint +/- 2%

Qualification Levels

(Per Report EGS-TR-23002-09)

- Qualified Life: 40 years at 135°F (57°C)
- Seismic:
 - Horizontal 15.0g peak, 6.5g ZPA at 5.0% damping
 - Vertical 15.0g peak, 6.5g ZPA at 5.0% damping
- Radiation: 6.35E7 rads gamma
- Cycling: 2200 operational cycles under full-rated load
- Accident Peaks: 355°F (179°C)

(See graph on back)

Qualification Standards

Successfully qualified by test in accordance with:

- ASME
- ANSI N45.2
- 10CFR50/Appendix B
- 10CFR21
- NQA-1
- IEEE 323-1974/1983/2003
- IEEE 344-1975/1987/2004

EGS Temperature Switch

- Moisture resistant seal
- Extra lead length available
- Stainless steel construction
- Temperature adjustment screw

Mounting Base (Optional)

Mount with #4 screws, flat washers, nuts, and lock washers. This optional mounting base uses the 1/2" NPT threads for mounting.

See installation instructions EGS-TR-23002-14 for qualified mounting configurations.

How to Order

EGS Temperature Switches are provided in either a normally open (N.O.) or normally closed (N.C.) state. Normally open switch closes on rising temperature. Part numbers for ordering are shown in the table to the right.

Indicate desired setpoint temperature in degrees Fahrenheit on order.

QDC Socket Side Assembly Purchased Separately - Required to meet qualified configuration.

Standard length is 20', additional lengths available upon request.

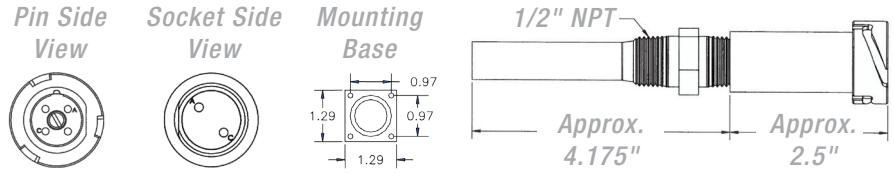
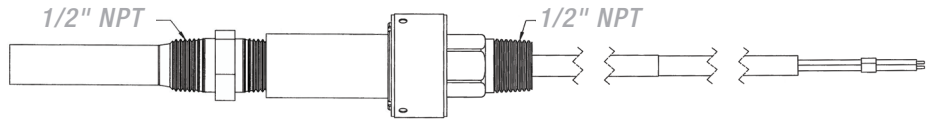

Temperature Switch Order Numbers

Contact State	N.O.	N.C.
EGS Part Number	23002-07	23002-08
Direct Replacement Fenwal Model	17023-6	17002-40
Obsolete EGS Model	01-170230-0	01-170020-0

1/2" QDC Socket Side Assembly

Contact State	EGS Part Number
N.O.	23002-09
N.C.	23002-10

Mounting Base Order Number

EGS Part Number	
Mounting Base	23002-06

LOCA Temp Profile for EGS Temp Switch
(Pressures based on Superheated conditions for first 10 Hours then Saturated Conditions for remainder)

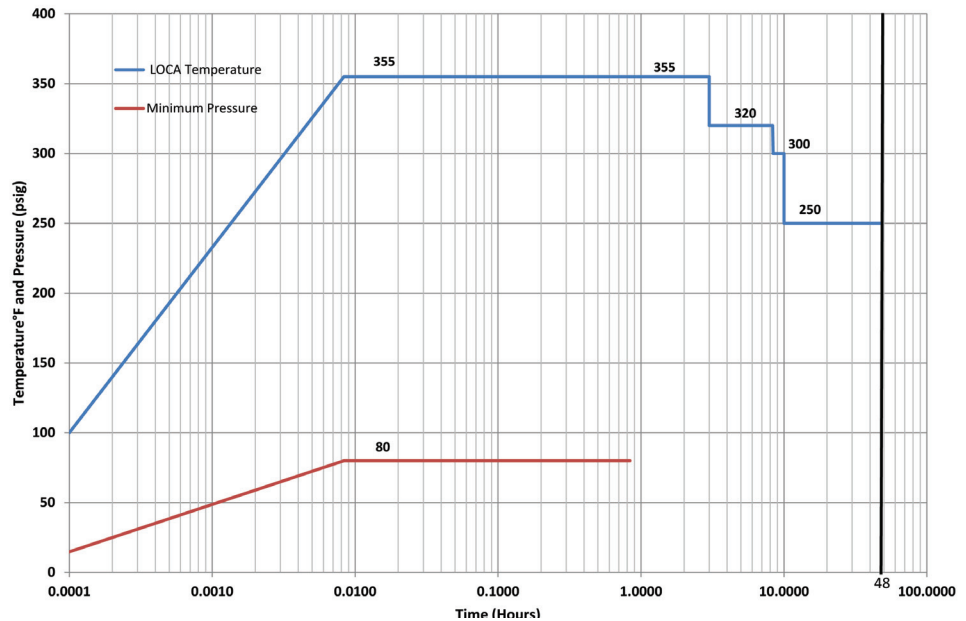

CONTACT INFORMATION:

18001 Sheldon Road, Middleburg Hts., OH 44130
electricalconnections@curtisswright.com | +1.216.267.3200

Specialty Cable Assembly

**CURTISS -
WRIGHT**

Nuclear Power Products and Services



Product Description

Curtiss-Wright Nuclear provides Class 1E Specialty Cable Assemblies for use inside or outside containment in nuclear power plants. The Specialty Cable Assembly is qualified for the following functions:

- In-Core Instrumentation (ICI)
- Heated Junction Thermocouple (HJTC)
- Control Element Drive Mechanism (CEDM) Power
- Air Handling Unit (AHU) Fan Power and Instrumentation
- Reed Switch Position Transmitter (RSPT)
- Core Exit Thermocouple (CET)
- Control Rod Drive Mechanism (CRDM)
- In-Core Neutron Monitoring/Self-Powered Neutron Detector (SPND)
- Penetration Connections

Design Features

- Mate to existing plugs/receptacles
- Generic qualification to environmental and seismic environments
- Can utilize Veam, Bendix, Amphenol, or other connectors
- Replaces NSSS or A/E supplied cable assemblies
- Mineral insulated (MI) cable assemblies available
- Fiber optic cable assemblies available

Qualification Levels

- Qualified Life: 40 years at 170°F
- Radiation: 2E8 rads
- LOCA: tested to 380°F/70 psig (193.33°C/584.0 kPa), chemical spray and 100% R.H.

Qualification Standards

Successfully qualified by test in accordance with:

- IEEE 323
- IEEE 344
- IEEE 572

How to Order

Cables are custom made per order. Contact EGS product engineering for inquiries.

CONTACT INFORMATION:

18001 Sheldon Road, Middleburg Hts., OH 44130
electricalconnections@curtisswright.com | +1.216.267.3200

Nuclear
CWNUCLEAR.COM

TD - 320 - 09.2024 - EGS

EGS Hi/Lo Pressure Seal

for Seal Table

**CURTISS -
WRIGHT**

Nuclear Power Products and Services

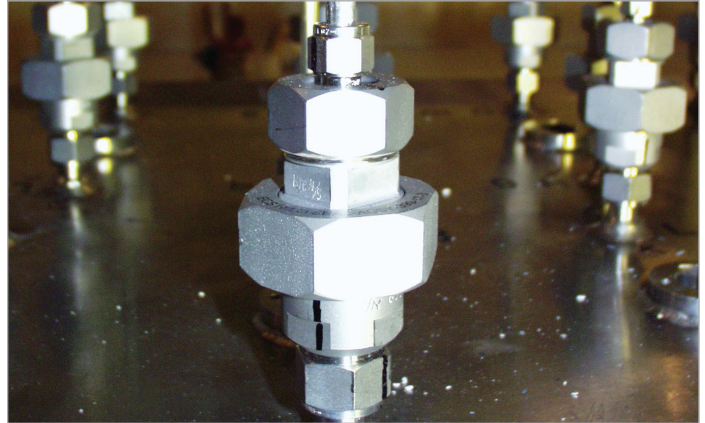
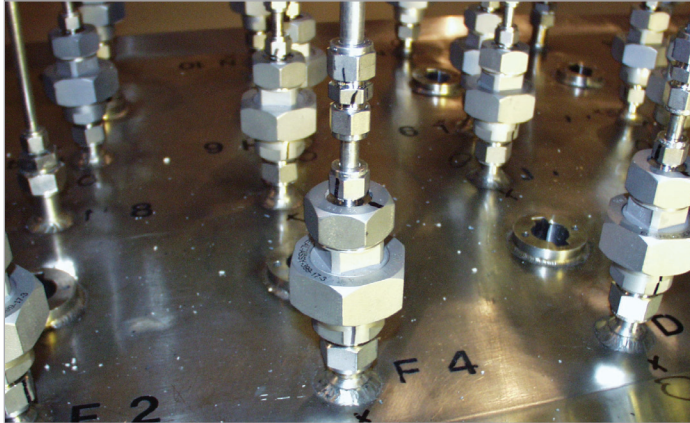

Product Description

A new idea for sealing of in-core instrumentation thimble tubes. Curtiss-Wright's nuclear qualified EGS product line includes an innovative combination Hi/Lo Pressure Seal for seal table use on Westinghouse PWRs.

The Hi/Lo Pressure Seal replaces an existing Swagelok™ adapter fitting and retains the metal-to-metal sealing characteristics currently in use. The seal can therefore be accepted via an equivalency determination since:

- The material is the same (stainless steel)
- Seismic qualification proven by testing and/or analysis (performed by Curtiss-Wright)

The Hi/Lo Pressure Seal also functions in the low-pressure mode, with no added configuration. The new seal permits thimbles to be withdrawn by simply removing a 1.5-inch union nut and loosening a 2.0-inch union nut. Tightening the 2.0-inch nut after thimble withdrawal maintains the low-pressure seal and secures the thimble in place. After refueling, the process is reversed and the two unions are tightened to specific torque values. The Hi/Lo Pressure Seal will reduce radiation exposure, labor costs, maintenance expenditures, and outage time.

The Hi/Lo Seal can be customized to fit any configuration.

Qualification Levels

- Qualified Life: >40 years at 150°F (65.56°C)
- Vibration Aging: None
- Radiation: 5E6 rads gamma
- Seismic: EGS generic TRS (*See seismic graph below*)
- Cycles: 40 cycles
- LOCA: Not applicable
- Fluid: Borated water at 2500 psig/150°F (service) (17,338.3 kPa/65.56°C)
 - Tested to 3,750 psig (25,956.7 kPa)

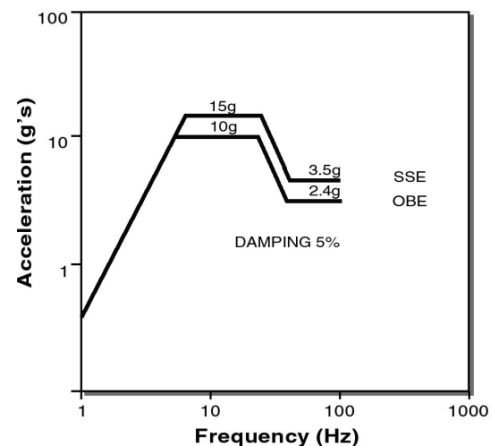

Note: Horizontal and vertical generic qualification level required response spectra (RRS).

CONTACT INFORMATION:

18001 Sheldon Road, Middleburg Hts., OH 44130
electricalconnections@curtisswright.com | +1.216.267.3200

Nuclear Power Products and Services

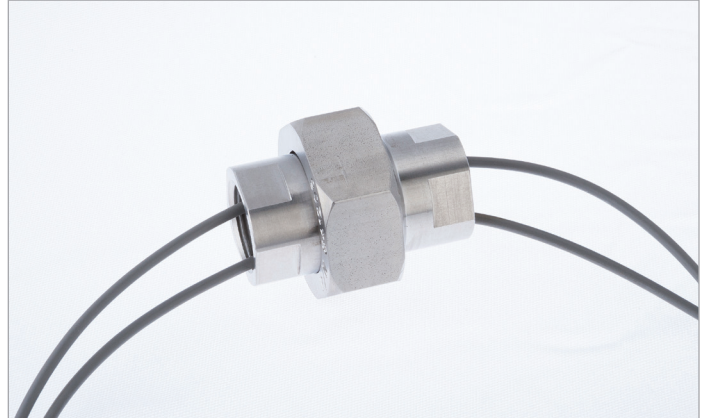
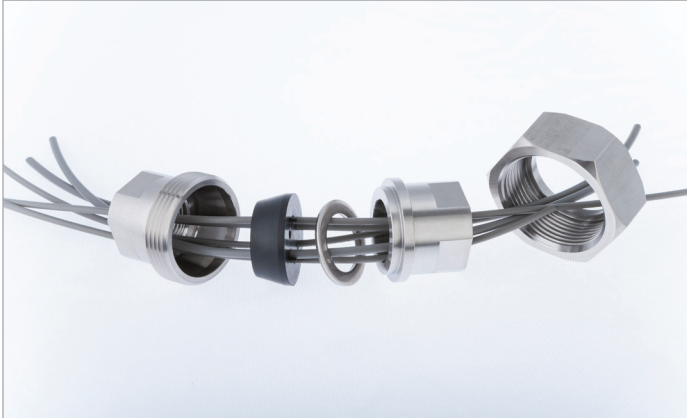

Product Description

The EGS Conduit Seal is a lightweight, easy-to-install design that prevents moisture and water from penetrating instrument housings or junction boxes from attaching conduits. Its anatomy consists of two stainless steel housings that are assembled with a hex nut. The housings contain a grommet. The wires are fed through the grommet's specially sized holes. The housings are tightened using the hex nut, which compresses the grommet and creates the seal.

Design Features

- Easy installation/simple assembly procedures
- Multi-conductor capability up to six #12 or #14 AWG, or up to eight #16 or #18 AWG
- Avoids twisting of lead wire
- Small and lightweight, less than one pound
- Utilizes existing field wire, no splicing
- No special tools or preassembly required
- No maintenance
- Coarse threads
- Easy interface with device and conduit
- Used on variety of devices such as solenoid valves, transmitters, RTDs, TCs, pressure/limit/level/position switches, etc.
- Compatible with ALARA considerations

Qualification Levels

- Qualified life: 40 years at 150°F (65°C)
- Radiation: 2E8 rads gamma
- Seismic: 6.0g ZPA
- LOCA: tested to 415°F (212°C) and
- 100 psig (790.8 kPa)

Qualification Standards

Successfully qualified by test for applications in harsh PWR/BWR environments, in accordance with:

- ANSI N45.2
- 10CFR50/Appendix B
- 10CFR50.49
- IEEE Standards (vary per applicable EQ Qualification Report)
- CSA Registered

EGS Conduit Seal

Qualification Levels

(Per EGS Report PEI-TR-841203-12)

First Test

- Qualified life: 40 years at 150°F (65°C)
- Seismic:
 - 4.0g ZPA (OBE)
 - 6.0g ZPA (SSE)
- Vibration Aging: 0.75g, 90 minutes per axis
- Radiation: 2E8 rads gamma
- Accident Peaks: tested to 415°F (212°C), 100 psig (790.8 kPa), chemical spray, 100%RH (See figure below)

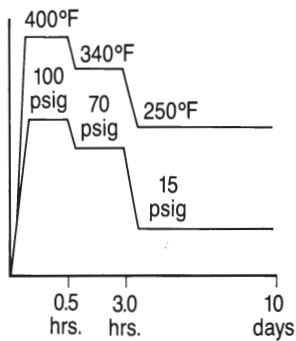

Second Test

- Qualified life: 5 years at 195°F (90°C)
- Radiation: 5.7E7 rads gamma
- Accident Peaks: 340°F (171°C), 55 psig (480.6 kPa), demineralized waterspray, 100%RH (See figure below)

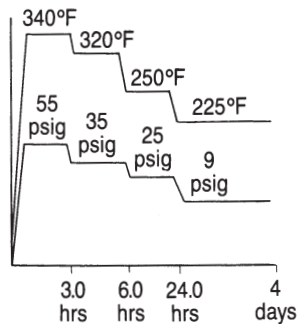

Installation

Installation is simple and easy. The conduit seal is designed for quick, cost-effective installation into instruments, junction boxes or conduit runs. No special tools or preassembly is required. Responses from installation teams indicate that the EGS Conduit Seal is durable and can be installed in a fraction of the time required for other nuclear seals.

Typical Configuration

1. Field Conduit
2. Housing, High Pressure Side to Field Conduit
3. Union Nut
4. Flat Washer
5. Grommet
6. Steel Ball
7. Housing, Low Pressure Side to Instrument Adapter
8. Instrument Housing
9. Insulated Wire
10. Cable Jacket
11. Cable Jacket

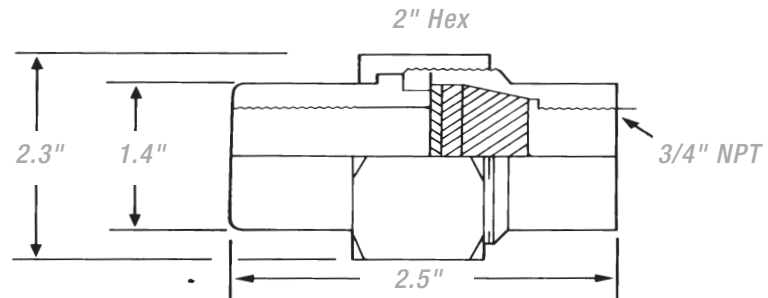
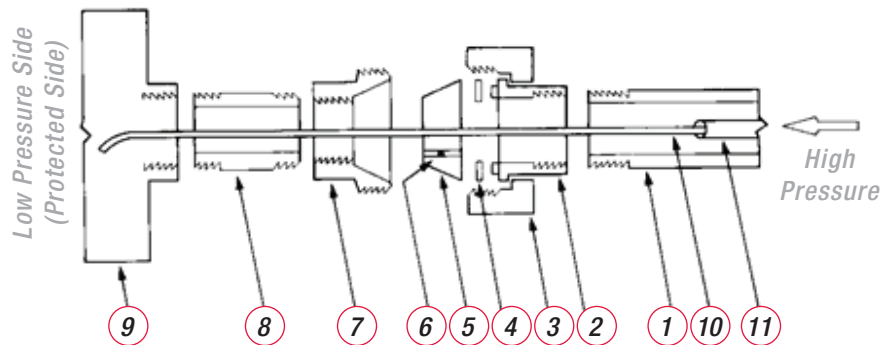

How to Order

The EGS Conduit Seal housing is ordered by part number 841206. The grommets are ordered by unique part numbers based on lead wire diameters as shown.

Order Grommet Seal P/N	Nominal Lead Wire Diameter - inches (conductor with insulation)	Maximum Number of Lead Wire
GR-12	0.136-0.183	6
GR-14	0.120-0.158	6
GR-16	0.110-0.141	8
GR-18	0.088-0.122	8

Example: Conduit Seal required for device with six, 0.160 diameter wires, would be part number: 841206/GR-12

CONTACT INFORMATION:

18001 Sheldon Road, Middleburg Hts., OH 44130
 electricalconnections@curtisswright.com | +1.216.267.3200

Nuclear Power Products and Services

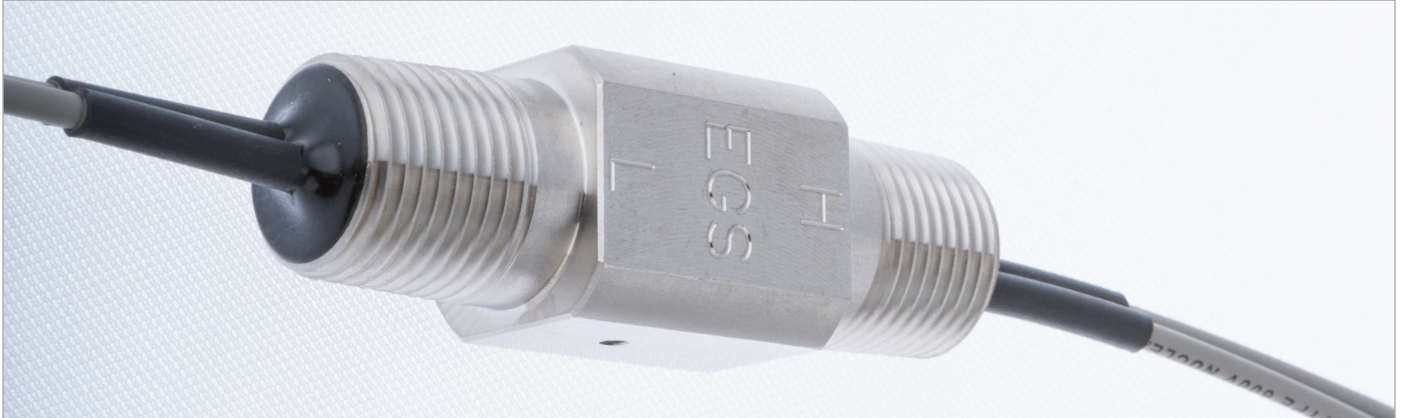

Product Description

The EGS Electrical Conduit Seal (ECSA) is a lightweight, multi-conductor interface that provides a pressure boundary to prevent the passage of moisture/water from the conduit into instrument housings or junction boxes. It is a factory assembled conduit seal consisting of a stainless steel housing with integral feed through wiring and epoxy sealant. The ECSA is a passive device with no moving parts.

Design Features

- Easy Installation
- Multi-conductor capability
- Small and lightweight
- No maintenance
- Easy interface with device and conduit
- Used on a variety of devices such as RTDs, solenoid valves, TCs, transmitters, MOVs, pressure/limit/level/position switches, etc.
- Compatible with ALARA considerations

Qualification Levels

- Qualified life: 40 years at 150°F (65°C)
- Radiation: 2E8 rads gamma
- Seismic: 8.3 g's ZPA
- LOCA: tested to 435°F (223.9°C) and a pressure of 77 psig (632.2 kPa)
- Supplied under a quality assurance program in accordance with ANSI N45.2 and 10CFR50, Appendix B
- CSA registered

Qualification Standards

Successfully qualified by test in accordance with:

- IEEE 572-1985
- IEEE 323-1974/1983
- IEEE 344-1975/1987
- IEEE 382-1980
- 10CFR50.49

EGS BLUEBOOT Connector Series

Non-Safety Related

**CURTISS -
WRIGHT**

Nuclear Power Products and Services



Product Description

The EGS BLUEBOOT is a compact, easy-to-install design to be used as an alternative to splicing, terminal blocks, and large multi-pin connectors.

The EGS BLUEBOOT connector is a single conductor quick-disconnect for non-safety related applications. Similar to the safety-related GRAYBOOT, it is an elastomer body/sealed connector whose performance is equivalent to heat shrink tubing or uninterrupted wire with regard to insulation resistance and leakage current. This connector typically features plated contacts crimped to the user's field wiring and inserted into the connector body. Sealing is maintained at the wire to body interface and at the connector halves by the elastomer to elastomer seal. No maintenance is required.

Design Features

- Quick connect/disconnect (push/pull)
- Easy installation
- Small size for conduit and instrument enclosure use
- Eliminates splicing problems
- Utilizes existing pigtails/field wire
- No maintenance
- High insulation resistance
- Low current leakage
- Better performance than most splices, terminal blocks and connectors
- Quick installation tools available
- Allows for easy transition from large wire to small wire
- Temperature range: -193°F to 199°F (-125°C to 93°C)
- Blue cosmetic visually distinguishes from EGS EQ qualified GRAYBOOT
- Cover clamps not necessary

BLUEBOOT Connector Series

Non-Safety Related

BLUEBOOT Connector Specifications

Item	Description	Material
1	Plug Boot	Neoprene
2	Receptacle Boot	Neoprene
3	Socket	Copper alloy (plating varies by size)
4	Pin	Copper alloy (plating varies by size)
5	Cover Clamp	Not included
6	Wire	Supplied by plant

Installation

Installation is quick and easy. Wire ends (6) are stripped and the pin (4) and socket (3) are crimped to their respective ends. The insertion tool is then used to grasp the pin or socket and push it into place in the boots (1 or 2).

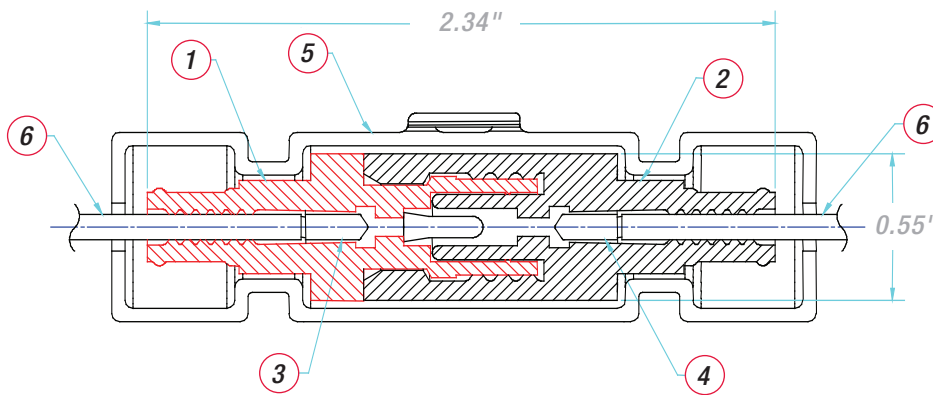

CONTACT INFORMATION:

18001 Sheldon Road, Middleburg Hts., OH 44130
electricalconnections@curtisswright.com | +1.216.267.3200

EGS BLUEBOOT Selection Guide

For BB-1 Series (<1000 Volt Applications)



How to Order

The EGS BLUEBOOT is ordered by P/N and conductor size per the following sample table:

P/N	Description
BB-1(12-14)	Connector Kit for 12 through 14 AWG wire
BB-1(16-26)	Connector Kit for 16 through 26 AWG wire
BB-1(12-14/16-26)	Connector Reducer Kit for 12 or 14 to 16 through 26 AWG wire

More kit sizes are available in the following selection guides.

Conductor		Insulation OD (inches)	
Side A AWG	Side B AWG	Side A $I_{od}^{(1)}$	Side B $I_{od}^{(1)}$
26-16	26-16	.080-.170 ⁽²⁾⁽³⁾	.160-.250 ⁽²⁾
26-16	14-12	.080-.170 ⁽²⁾⁽³⁾	.160-.250 ⁽²⁾
14-12	14-12	BB-1 (16-26)	BB-1 (12-14/16-26) OS
		BB-1 (12-14)	BB-1 (12-14) OS

BB-1 Notes:

- I_{od} = Insulation outside diameter.
- For applications where the wire insulation OD is less than the minimum specified 0.080" or 0.160", a heat shrink shim must be utilized to increase the substrate diameter to an acceptable value.

EGS BLUEBOOT Selection Guide

For BB-2 and BB-3 Series (<600 Volt Applications)



The table presented below helps the user determine which particular BLUEBOOT Kit is required for different insulation and wire sizes. The user can correlate insulation outside diameter with wire gauge to determine proper BLUEBOOT Kit required for a particular application.

Side A and Side B used in table below can be used for either the device side or field side. Except for the BB-S-2 and BB-S-3 kits, it is general practice to install the socket on the field side.

Conductor	Insulation OD (inches)	
	Side A I _{OD} ⁽¹⁾	Side B I _{OD} ⁽¹⁾
Side A Pin Side Plug Boot AWG	Side B Socket Side Recept. Boot AWG	
16-18	16-18	.140-.280 ⁽²⁾ BB-2 (16-18)
12-14	12-14	.140-.280 ⁽²⁾ BB-2 (12-14)
16-18	12-14	.140-.280 ⁽²⁾ BB-2 (12-14/16-18)
12-18	8-10	.140-.280 ⁽²⁾ BB-2 (8-10/12-18)
12-14	8-10	.140-.280 ⁽²⁾ BB-2 (8-10/12-14)
8-10	8-10	.140-.280 ⁽²⁾ BB-2 (8-10)
4-10	8-18	.270-.425 ⁽²⁾ BB-S-3
4-6	8-14	.270-.425 ⁽²⁾ BB-S-2
8-10	8-10	.270-.425 ⁽²⁾ BB-3 (8-10)
8-10	4-6	.270-.425 ⁽²⁾ BB-3 (4-6/8-10)
4-6	4-6	.270-.425 ⁽²⁾ BB-3 (4-6)

BB-2 and BB-3 Notes:

- I_{OD} = Insulation outside diameter (inches).
- For applications where the wire insulation OD is less than the minimum specified 0.140", or 0.270", a heat shrink shim must be utilized to increase the substrate diameter to an acceptable value.

CONTACT INFORMATION:

18001 Sheldon Road, Middleburg Hts., OH 44130
 electricalconnections@curtisswright.com | +1.216.267.3200

EGS GRAYBOOT Connector Series

**CURTISS -
WRIGHT**

Nuclear Power Products and Services



Product Description

The EGS GRAYBOOT connector is a single conductor, quick-disconnect, elastomer body, sealed connector whose performance in accident conditions is equivalent to nuclear grade heat shrink tubing or uninterrupted nuclear grade wire with regard to insulation resistance and leakage current. This connector typically features plated contacts crimped to the user's field wiring and inserted into the connector body. The connector halves are then secured to the wire by a special crimp-clamp. Sealing is maintained at the wire to body interface by the clamp and at the connector halves by the elastomer to elastomer seal. No maintenance is required.

Design Features

- Quick connect/disconnect (push/pull)
- Easy installation
- Small size for conduit and instrument enclosure use
- Eliminates splicing problems
- EQ tested including submergence
- Utilizes existing pigtails/field wire
- Anti-tamper clamps available
- No maintenance
- High insulation resistance during LOCA
- Low current leakage for instrument sizes
- 600V rating, up to 85 amps
- ALARA savings over repetitive splicing
- Better performance than most splices, terminal blocks and connectors
- Quick installation tools available
- Allows for easy transition from large wire to small wire
- Continuous Use Temperature 257°F (125°C)

Qualification Levels *(See graph on back)*

- Qualified life: 40 years at 133°F (56°C)
- Radiation: 2E8 rads gamma
- Seismic: 7.0g ZPA
- LOCA Tested: 435°F (223°C) and 77 psig (632.2 kPa)
- Accident Peaks
- Submergence: 30 days at 200/180°F (93/82°C) and 15/5 psig (204.8/135.8 kPa) in chemical spray solution

Qualification Standards

Successfully qualified by test in accordance with:

- ANSI N45.2
- 10CFR50/Appendix B
- 10CFR21
- NQA-1
- CSA registered
- IEEE 323-1974/1983
- IEEE 344-1975/1987
- IEEE 383-1974
- IEEE 572-1985
- 10CFR50.49

EGS GRAYBOOT Connector Series

EGS GRAYBOOT Connector Specifications (Partial List)

Parameter	GB-1 (16-18)	GB-1 (12-14)	GB-2 (12-14)	GB-2 (8-10)	GB-3 (4-6)
AWG Range	16-18	12-14	12-14	10-8	6-4
Rated Voltage (volts)	600	600	600	600	600
Rated Current (amps)	13	23	30	46	85
Rated Contact Resistance (ohms)	0.0026	0.0013	0.0013	0.0005	0.0004
Insulated Wire Diameter Use Range (inches)	0.090-0.160	0.090-0.160	0.160-0.280	0.160-0.280	0.270-0.425

Notes:

- Individual components such as pins/sockets can be ordered per part numbers shown on GRAYBOOT Assembly Drawings A-N-880707- 1, -2 or -3
- For additional kit P/N and configurations, refer to the GRAYBOOT Selection Guide

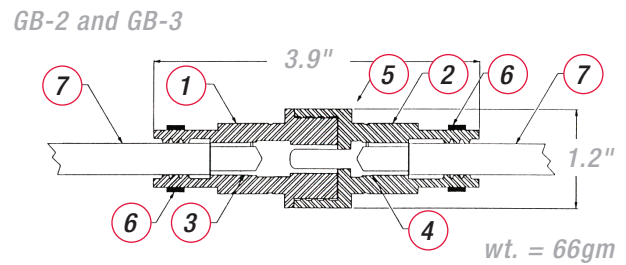
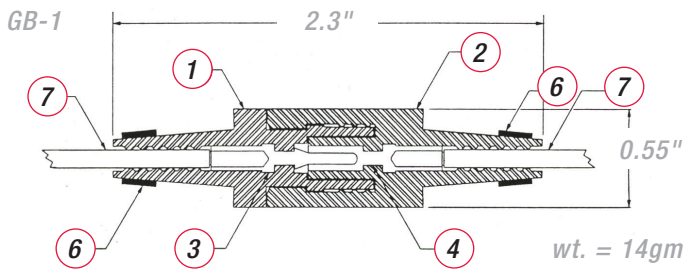

Installation (See diagram to right)

Installation is quick and easy. Wire ends (7) are stripped and the pin (4) and socket (3) are crimped to their respective ends. One clamp (6) is slipped loosely over each end of the wire and moved down the wire for later crimping. The insertion tool is then used to grasp the pin or socket and push it into place in the boots (1 or 2). The clamps (6) are now crimped. If desired, an anti-tamper clamp (5) may be snapped over the mated connector.

Item	Description	Material
1	Plug Boot	EPDM
2	Receptacle Boot	EPDM
3	Socket	Base: Cooper Alloy
4	Pin	Plating: Au for GB-1 (16-18), Ag for GB-1 (12-14), SnPb for GB-2/GB-3
5	Cover/Clamp	Polypropylene for GB-1 diameter 0.82" Polyketone for GB-2/GB-3 diameter 1.5"
6	Wire Clamp	Stainless Steel 300 Series
7	Wire	Supplied by Plant

Installation tools include:

- P/N GB-1A-1K (installation kit for GB-1)
- P/N GB-2/3-1K (installation kit for GB-2 and GB-3)
- P/N TBM-6S (crimp tool for GB-2 and GB-3)

Refer to GRAYBOOT Selection Guide for additional information.

How to Order

The EGS GRAYBOOT is ordered by P/N and conductor size per the Selection Guide.

Qualification Levels: EGS Report EGS-TR-880707-04

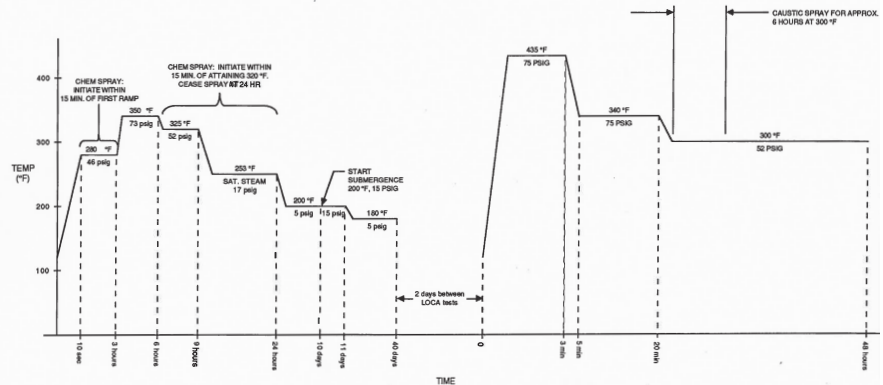

CONTACT INFORMATION:

18001 Sheldon Road, Middleburg Hts., OH 44130
electricalconnections@curtisswright.com | +1.216.267.3200

Nuclear Power Products and Services

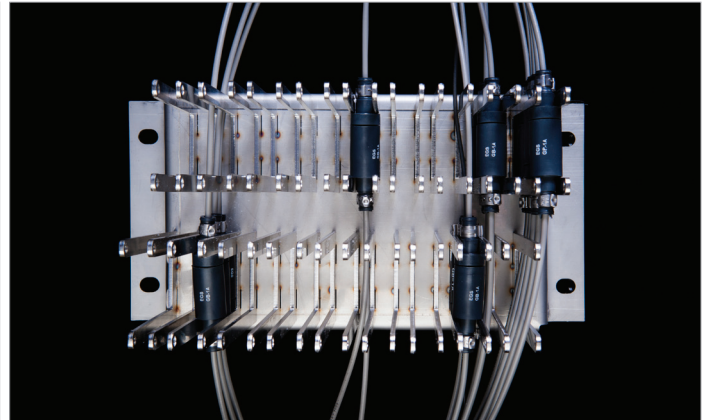
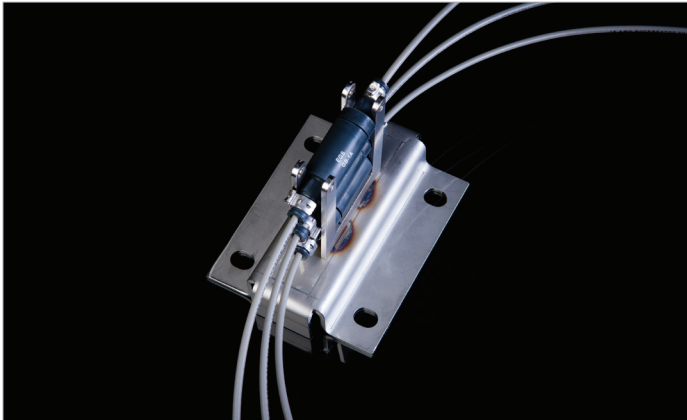

Product Description

The GRAYBOOT Rack is a rugged and easy-to-install device that organizes multiple splice areas such as an electrical enclosure. The rack provides easier splice identification for good housekeeping and overall organized appearance.

The GRAYBOOT Rack is a multi-splice mechanical device that provides for up to 108 GRAYBOOT splices to be organized, and secured within an electrical enclosure. The Rack consists of two stainless steel partitions which secure the GRAYBOOT Splices in an organized fashion. To prevent the GRAYBOOTS from exiting the channel, secure the ends of the rack with wire (not included).

Design Features

- Easy installation/simple assembly procedures
- Multi-splice capability (up to 6 GB-1 splices per row without cover clamp)
- Avoids messy and confusing multiple splice locations
- 304SST
- Custom mounting footprint available
- No special tools or preassembly required
- No maintenance
- Compatible with ALARA considerations

Qualification Levels

- Seismic: ZPA of 6.0g horizontal & 7.3 ZPA vertical
- Supplied under a quality assurance program in accordance with ANSI N45.2 and 10CFR50, Appendix B

Qualification Standards

Successfully qualified by test in accordance with:

- IEEE 344-1987

How to Order

The GRAYBOOT Rack is ordered by part number.

- **23047-124** – Single Row Multiple Splice Rack
- **23047-123** – Dual Row Multiple Splice Rack

Note: The GRAYBOOT rack is provided with a standard mounting configuration but may be modified if required. (See diagram below)

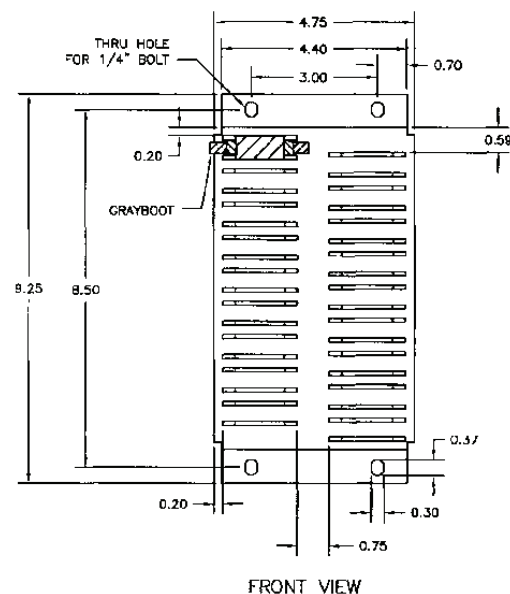

CONTACT INFORMATION:

18001 Sheldon Road, Middleburg Hts., OH 44130
 electricalconnections@curtisswright.com | +1.216.267.3200

EGS GRAYBOOT “A” Connector Series

**CURTISS -
WRIGHT**

Nuclear Power Products and Services

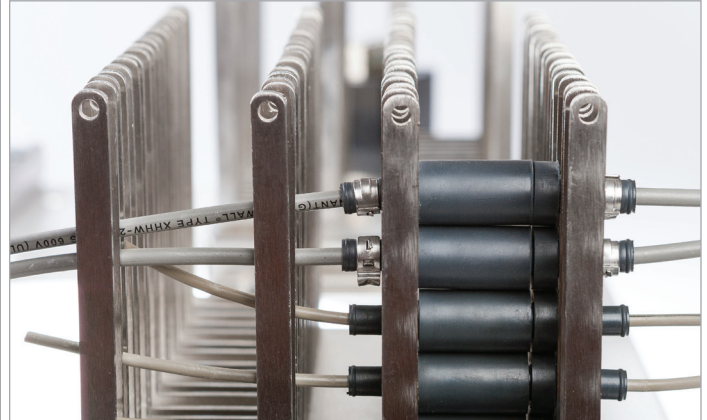
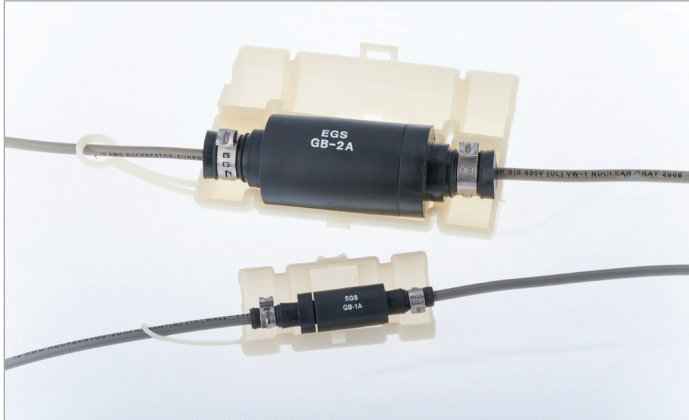

Product Description

The EGS GRAYBOOT “A” connector is a single conductor, quick-disconnect, elastomer body, sealed connector whose performance is equivalent to nuclear grade heat shrink tubing or uninterrupted nuclear grade wire with regard to insulation resistance and leakage current. This connector features gold or silver plated contacts crimped to the user’s field wiring and inserted into the connector body. The connector halves are then secured to the wire by a special crimp-clamp. Sealing is maintained at the wire to body interface by the clamp and at the connector halves by the elastomer to elastomer seal. No maintenance is required.

The GRAYBOOT “A” is an improved design over the original GRAYBOOT (extended use ranges, optional wire clamps for GB-1A). The GB-1A connectors are interchangeable with the GB-1 connectors.

Design Features

- Quick connect/disconnect (push/pull)
- Easy installation
- Small size for conduit and instrument enclosure use
- Eliminates splicing problems
- EQ tested including submergence
- Utilizes existing pigtails/field wire
- Anti-tamper clamps available
- No maintenance
- High insulation resistance during LOCA
- Low current leakage for instrument sizes
- 600V rating, up to 46 amps (1000V outside containment)
- ALARA savings over repetitive splicing
- Better performance than most splices, terminal blocks and connectors
- Quick installation tools available
- Allows for easy transition from large wire to small wire
- Continuous Use Temperature 257°F (125°C)

Qualification Levels

(Per EGS Report EGS-TR-1038.2-08)

- Qualified life: 40.2 years at 150°F (65.6°C)
- Radiation: 2.1E8 rads gamma
- Submergence: 30 days
- Extended Submergence: 409 days
- Accident Peaks: 448°F/102 psig (231°C/825.3 kPa)

(See figure below)

Qualification Standards

Successfully qualified by test in accordance with:

- ANSI N45.2
- 10CFR50/Appendix B
- 10CFR21
- NQA-1
- CSA registered
- IEEE 323-1974/1983
- IEEE 344-1975/1987
- IEEE 572-1985
- 10CFR50.49

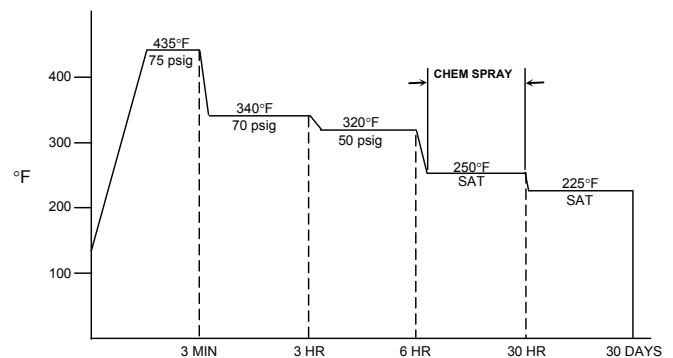

EGS GRAYBOOT "A" Connector Series

EGS GRAYBOOT "A" Connector Specifications (Partial List)

Parameter	GB-1A (16-18)	GB-1A (12-14)	GB-2A (12-18)	GB-2A (8-10)	GB-3A (4-6)
AWG Range	16-18	12-14	12-18	10-8	6-4
Rated Voltage (volts)	600	600	600	600	600
Rated Current (amps)	13	23	30	46	85
Rated Contact Resistance (ohms)	0.0026	0.0013	0.0005	0.0005	0.0004
Insulated Wire Diameter Use Range (inches)	0.080-0.170	0.080-0.170	0.140-0.280	0.140-0.280	0.270-0.425

Notes:

- Individual components such as pins/sockets can be ordered per part numbers shown on GRAYBOOT "A" Assembly Drawings A-N-1038.1-6, -7, -8, -9, -10, -17, or -21
- For additional kit P/N and configurations, refer to the GRAYBOOT "A" Selection Guide

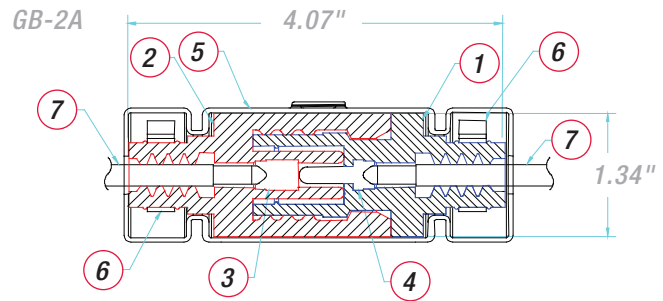
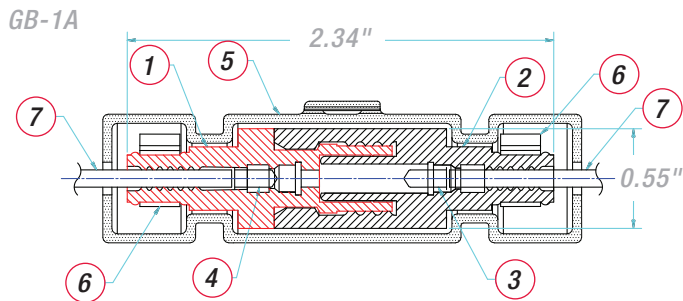

Installation (See diagram above)

Installation is quick and easy. Wire ends (7) are stripped and the pin (4) and socket (3) are crimped to their respective ends. One clamp (6) is slipped loosely over each end of the wire and moved down the wire for later crimping. The insertion tool is then used to grasp the pin or socket and push it into place in the boots (1 or 2). The clamps (6) are now crimped. If desired, an anti-tamper clamp (5) may be snapped over the mated connector.

Item	Description	Material
1	Plug Boot	EPDM
2	Receptacle Boot	
3	Socket	Cooper Alloy (gold plated for GB-1A and silver plated for GB-2A and GB-3A)
4	Pin	
5	Cover/Clamp	Polyketone (non-safety-related, optional, diameter 0.82 for GB-1A, diameter 1.5 for GB-2A and GB-3A)
6	Wire Clamp	Stainless Steel 300 Series
7	Wire	Supplied by Plant or EGS

Installation tools include:

- P/N GB-1A-IK (installation kit for GB-1A)
- P/N GB-2/3A-IK (installation kit for GB-2A and GB-3A)
- P/N TBM-6S (crimp tool for GB-2A and GB-3A)

Refer to GRAYBOOT "A" Selection Guide for additional information.

How to Order

The EGS GRAYBOOT "A" is ordered by P/N and conductor size per the Selection Guide.

CONTACT INFORMATION:

18001 Sheldon Road, Middleburg Hts., OH 44130
 electricalconnections@curtisswright.com | +1.216.267.3200

EGS GRAYBOOT “A” Selection Guide

For GB-1A Series GRAYBOOT “A” Connectors



The table presented below helps user determine which particular GRAYBOOT “A” Kit is required for different insulation and wire sizes. Users can correlate insulation outside diameter with wire gauge to determine proper GRAYBOOT “A” Kit required for a particular application.

Side A and Side B in the table below can be used for either the device side or field side for the standard kits (i.e., GB-1A (12-14) or GB-1A (16-18)). When utilizing the reduction kits, Side A is the pin side and is normally used on the device side (smaller wire size/insulation diameter) and Side B is usually used on the field side (larger wire size/insulation diameter). It should be noted that it is general practice to install connector such that socket is placed on field side.

Conductor		Insulation (inches)						
Side A Pin Side Plug Boot AWG	Side B Socket Side Recept. Boot AWG	Side A I _{op} ⁽¹⁾	.05-.080	.05-.080	.080-.170	.05-.080	.080-.170	.160-.250
		Side B I _{op} ⁽¹⁾	.05-.080	.080-.170	.080-.170	.160-.250	.160-.250	.160-.250
20-26	20-26		GB-1A (20-26) ⁽²⁾	GB-1A (20-26) ⁽³⁾	GB-1A (20-26)			
20-26	16-18		GB-1A (16-18/20-26) ⁽²⁾	GB-1A (16-18/20-26) ⁽³⁾	GB-1A (16-18/20-26)			
20-26	12-14		GB-1A (12-14/20-26) ⁽²⁾	GB-1A (12-14/20-26) ⁽³⁾	GB-1A (12-14/20-26)	GB-S-1A ⁽³⁾	GB-S-1A	
20-26	10-14					GB-S-1A ⁽³⁾	GB-S-1A	
16-18	16-18		GB-1A (16-18) ⁽²⁾	GB-1A (16-18) ⁽³⁾	GB-1A (16-18)			
16-18	12-14		GB-1A (12-14/16-18) ⁽²⁾	GB-1A (12-14/16-18) ⁽³⁾	GB-1A (12-14/16-18)	GB-S-1A ⁽³⁾	GB-S-1A	
16-18	10-14					GB-S-1A ⁽³⁾	GB-S-1A	
12-14	12-14				GB-1A (12-14)			GB-1A (10-14)OS
10-14	10-14							GB-1A (10-14)OS

Notes (all measurements are in inches):

- I_{op} = Insulation outside diameter
- Requires WCSF-050-3/1 shim on both Side A and Side B.
- Requires WCSF-050-3/1 shim on Side A only.

Shim use range: WCSF-050-3/1 → 0.05-0.10"

EGS GRAYBOOT "A" Selection Guide

For GB-2A & GB-3A Series GRAYBOOT "A" Connectors



The table presented below helps user determine which particular GRAYBOOT "A" Kit is required for different insulation and wire sizes. Users can correlate insulation outside diameter with wire gauge to determine proper GRAYBOOT "A" Kit required for a particular application.

Side A and Side B in the table below can be used for either the device side or field side - except for the GB-S-2A and GB-S-3A kits where it is general practice to install the socket on the field side.

Conductor	Side B Socket Side Recept. Boot AWG	Side A L _{top} (1)		Insulation (Inches)												
		Side A L _{top} (1)	Side B L _{top} (1)	.083-.140	.083-.140	.140-.280	.140-.280	.165-.270	.165-.270	.270-.425 ⁽⁶⁾	.270-.425 ⁽⁶⁾	.165-.270	.165-.270	.270-.425 ⁽⁶⁾	.270-.425 ⁽⁶⁾	
16-18	16-18	GB-2A (16-18) ⁽²⁾	GB-2A (16-18) ⁽³⁾	GB-2A (16-18) ⁽²⁾	GB-2A (16-18) ⁽³⁾	GB-2A (16-18) ⁽²⁾	GB-2A (16-18) ⁽³⁾	GB-2A (16-18) ⁽²⁾	GB-2A (16-18) ⁽³⁾	GB-S-3A ⁽⁶⁾	GB-S-3A ⁽⁷⁾	GB-S-3A ⁽⁸⁾	GB-S-3A	GB-3A(8-10) ⁽⁶⁾	GB-3A(8-10) ⁽⁷⁾	GB-3A(8-10)
12-14	12-14	GB-2A (12-14) ⁽²⁾	GB-2A (12-14) ⁽³⁾	GB-2A (12-14) ⁽²⁾	GB-2A (12-14) ⁽³⁾	GB-2A (12-14)	GB-2A (12-14)	GB-2A (12-14)	GB-2A (12-14)					GB-3A(4-6) ⁽⁶⁾	GB-3A(4-6) ⁽⁷⁾	GB-3A(4-6)
16-18	12-14	GB-2A (12-14) ⁽²⁾	GB-2A (12-14) ⁽³⁾	GB-2A (12-14/16-18) ⁽²⁾	GB-2A (12-14/16-18) ⁽³⁾	GB-2A (12-14/16-18)	GB-2A (12-14/16-18)	GB-2A (12-14/16-18)	GB-2A (12-14/16-18)					GB-3A(4-6) ⁽⁶⁾	GB-3A(4-6) ⁽⁷⁾	GB-3A(4-6)
12-14	12-14	GB-2A (12-14) ⁽²⁾	GB-2A (12-14) ⁽³⁾	GB-2A (12-14/16-18) ⁽²⁾	GB-2A (12-14/16-18) ⁽³⁾	GB-2A (12-14/16-18)	GB-2A (12-14/16-18)	GB-2A (12-14/16-18)	GB-2A (12-14/16-18)					GB-3A(4-6) ⁽⁶⁾	GB-3A(4-6) ⁽⁷⁾	GB-3A(4-6)
16-18	12-14	GB-2A (12-14) ⁽²⁾	GB-2A (12-14) ⁽³⁾	GB-2A (12-14/16-18) ⁽²⁾	GB-2A (12-14/16-18) ⁽³⁾	GB-2A (12-14/16-18)	GB-2A (12-14/16-18)	GB-2A (12-14/16-18)	GB-2A (12-14/16-18)					GB-3A(4-6) ⁽⁶⁾	GB-3A(4-6) ⁽⁷⁾	GB-3A(4-6)
12-18	8-10	GB-2A (8-10/12-14) ⁽²⁾	GB-2A (8-10/12-14) ⁽³⁾	GB-2A (8-10/12-18) ⁽²⁾	GB-2A (8-10/12-18) ⁽³⁾	GB-2A (8-10/12-18)	GB-2A (8-10/12-18)	GB-2A (8-10/12-18)	GB-2A (8-10/12-18)					GB-3A(4-6) ⁽⁶⁾	GB-3A(4-6) ⁽⁷⁾	GB-3A(4-6)
12-14	8-10	GB-2A (8-10/12-14) ⁽²⁾	GB-2A (8-10/12-14) ⁽³⁾	GB-2A (8-10/12-14) ⁽²⁾	GB-2A (8-10/12-14) ⁽³⁾	GB-2A (8-10/12-14)	GB-2A (8-10/12-14)	GB-2A (8-10/12-14)	GB-2A (8-10/12-14)					GB-3A(4-6) ⁽⁶⁾	GB-3A(4-6) ⁽⁷⁾	GB-3A(4-6)
8-10	8-10	GB-2A (8-10) ⁽²⁾	GB-2A (8-10) ⁽³⁾	GB-2A (8-10) ⁽²⁾	GB-2A (8-10) ⁽³⁾	GB-2A (8-10)	GB-2A (8-10)	GB-2A (8-10)	GB-2A (8-10)					GB-3A(4-6) ⁽⁶⁾	GB-3A(4-6) ⁽⁷⁾	GB-3A(4-6)
4-10	8-18					GB-S-3A ⁽⁶⁾	GB-S-3A ⁽⁷⁾	GB-S-3A ⁽⁸⁾	GB-S-3A					GB-3A(4-6) ⁽⁶⁾	GB-3A(4-6) ⁽⁷⁾	GB-3A(4-6)
4-6	8-14					GB-S-2A ⁽⁶⁾	GB-S-2A ⁽⁷⁾	GB-S-2A ⁽⁸⁾	GB-S-2A					GB-3A(4-6) ⁽⁶⁾	GB-3A(4-6) ⁽⁷⁾	GB-3A(4-6)
8-10	8-10													GB-3A(4-6) ⁽⁶⁾	GB-3A(4-6) ⁽⁷⁾	GB-3A(4-6)
8-10	4-6													GB-3A(4-6) ⁽⁶⁾	GB-3A(4-6) ⁽⁷⁾	GB-3A(4-6)
4-6	4-6													GB-3A(4-6) ⁽⁶⁾	GB-3A(4-6) ⁽⁷⁾	GB-3A(4-6)

Notes (all measurements are in inches):

- L_{top} = Insulation outside diameter
- Requires WCSF-070-6/2 shim on both Side A and Side B.
- Requires WCSF-070-6/2 shim on Side A only.
- Requires WCSF-070-6/2 shim on Side B only.
- Requires WCSF-070-6/2 shim on Side B and requires WCSF-115-9/3 shim on Side A.
- Requires WCSF-115-9/3 shim on both Side A and Side B.
- Requires WCSF-115-9/3 shim on Side A only.
- Requires GB-3-11 wire clamp for insulation diameter larger than 0.340". Shim use range: WCSF-070-6/2 → 0.07-0.18" WCSF-115-9/3 → 0.115-0.29"

CONTACT INFORMATION:

18001 Sheldon Road, Middleburg Hts., OH 44130
 electricalconnections@curtisswright.com | +1.216.267.3200

EGS Flexible Metal Conduit



Nuclear Power Products and Services



Product Description

The EGS Flexible Metal Conduit is another member of the nuclear qualified EGS product line. In many cases, it is necessary to make electrical connections via a flexible conduit. For this application, the EGS Flexible Metal Conduit acts as a leak-tight pressure boundary in an accident environment. The flexible conduit utilizes all metallic construction (321 SST), thus eliminating concern for time-temperature/radiation aging effects. This lightweight conduit is available in 1/2" to 1-1/2" diameters. The ends may be equipped with male and female straight or swivel fittings (300 Series SST) as required. The conduit assembly is comprised entirely of stainless steel and is available in lengths from 18". Units are supplied in lengths as specified by the customer. Curtiss-Wright will assist, upon request, in selecting the proper length of conduit based on geometry and bend radius parameters of the various sizes of flexible conduit.

Design Features

- All stainless steel/welded construction
- Leak-tight pressure boundary
- Conduit diameters from 1/2" to 1-1/2"
- Lengths available from 18"
- Styles available with male, female or swivel fittings and integral reducers
- Lightweight
- Easy to install
- Useable temperature range from cryogenic to in excess of 1000°F (537.78°C)

Qualification Levels

- Radiation: Not affected by radiation due to all metallic construction
- Thermal Aging: Not affected by temperature due to all metallic construction
- Seismic: Tested in excess of 6.0g ZPA
- LOCA: tested to 412°F (211.1°C), 88 psig (708.1 kPa), chemical spray and 100% R.H.
- Supplied under a quality assurance program in accordance with ANSI N45.2 and 10CFR50, Appendix B

Qualification Standards

Successfully qualified by test in accordance with:

- IEEE 323-1974
- IEEE 344-1975
- IEEE 382-1980
- 10CFR50.49

Flexible Metal Conduit Parameters				
Diameter		Minimum Bend Radius (inches)		Wt/Ft (#/ft)
I.D. (inches)	O.D. (inches)	Flex Bend	Permanent Bend	
1/2	0.77	7.0	1.5	0.11
3/4	1.16	8.0	2.1	0.19
1	1.47	9.0	2.7	0.26
1-1/2	2.08	11.00	3.9	0.47

EGS Flexible Metal Conduit

How to Order

When ordering the flexible metal conduit, the following should be specified using the following part number scheme:

- A. Product Code
- B. Nominal Diameter
- C. Length
- D. First End Fitting
 - Style
 - Size
- E. Second End Fitting
 - Style
 - Size

Example: 841210 - 050 - 018 - 1CF - 1M

Stainless steel flexible metal conduit

A

Flex hose I.D.

B

Ref. No.	Size
050	0.50"
075	0.75"
100	1.00"
150	1.50"

Overall length (inches)
minimum length is 18".

C

Second end connection
(same identification as first end connection).

E

D First end connection

Ref. No.	Description
1-1/2SF	1-1/2" NPT Swivel Female
1-1/2M	1-1/2" NPT Male
1-1/2SM	1-1/2" NPT Swivel Male
1-1/2 90 SM	1-1/2" NPT 90° Swivel Male
1-1/2 45 SM	1-1/2" NPT 45° Swivel Male
1-3/4SM	1" to 3/4" NPT Swivel Male
1-3/4SF	1" to 3/4" NPT Swivel Female
1-1/2CF	1-1/2" NPT Coupling Female
1-3/4 90SM	1" to 3/4" NPT 90° Swivel Male
1-3/4 45SM	1-3/4" NPT 45° Swivel Male
1SF	1" NPT Swivel Female
1M	1" NPT Male
1SM	1" NPT Swivel Male
1 90 SM	1" NPT 90° Swivel Male
145 SM	1" NPT 45° Swivel Male
1CF	1" NPT Coupling Female
3/4F	3/4" NPT Female
3/4SF	3/4" NPT Swivel Female
3/4M	3/4" NPT Male
3/4SM	3/4" NPT Swivel Male
3/4 90 SM	3/4" NPT 90° Swivel Male
3/4 45 SM	3/4" NPT 45° Swivel Male
3/4CF	3/4" NPT Coupling Female
3/4-1/2SM	3/4" to 1/2" NPT Swivel Male
3/4-1/2SF	3/4" to 1/2" NPT Swivel Female
3/4-1SM	3/4" to 1" NPT Swivel Male
3/4-1/2 90SM	3/4" to 1/2" NPT 90° Swivel Male
3/4-1 90SM	3/4" to 1" NPT 90° Swivel Male
1/2F	1/2" NPT Female
1/2SF	1/2" NPT Swivel Female
1/2M	1/2" NPT Male
1/2SM	1/2" NPT Swivel Male
1/2 90 SM	1/2" NPT 90° Swivel Male
1/2 45 SM	1/2" NPT 45° Swivel Male
1/2CF	1/2" NPT Coupling Female
1/2 SE	1/2" NPT Street Elbow
1/2-3/4SM	1/2" to 3/4" NPT Swivel Male
1/2-3/4 90SM	1/2" to 3/4" NPT 90° Swivel

CONTACT INFORMATION:

18001 Sheldon Road, Middleburg Hts., OH 44130
electricalconnections@curtisswright.com | +1.216.267.3200

Compact Splice

for PWR/BWR Applications



Nuclear Power Products and Services

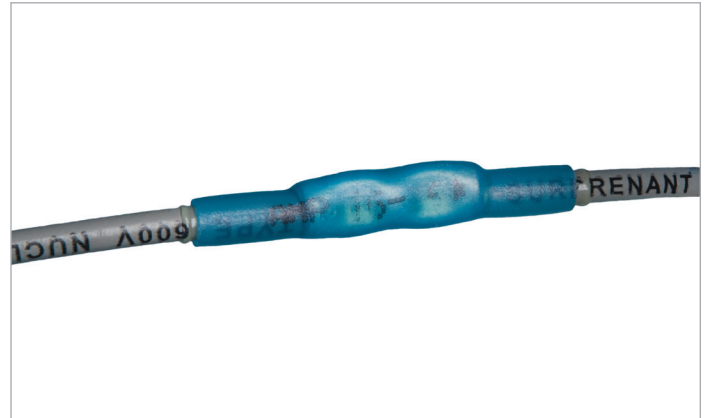
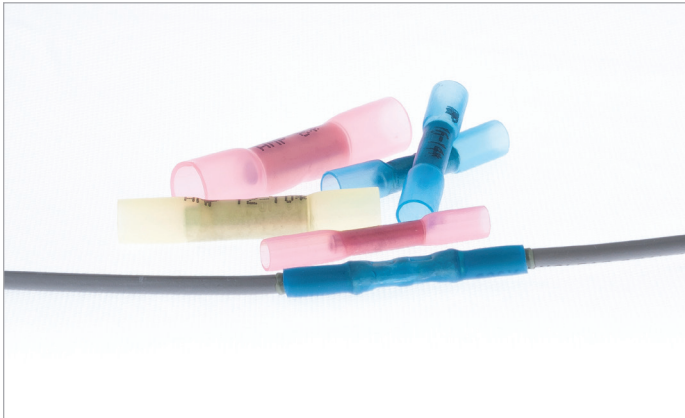

Product Description

The EGS Compact Splice is a light-weight, simple solution to single-conductor splicing needs. This splice can be installed, in plant, with little training and the use of a crimp tool and heat gun. The EGS Compact Splice has been CSA qualified for use with both solid conductor and stranded wire.

Qualification Levels

- Qualified life: 40 years at 150°F (65.6°C)
- Radiation: tested to 2.30E8 rads gamma
- LOCA: tested to 448°F (231°C) and 126 psig (970.1 kPa)

Qualification Standards

Successfully qualified by test (EGS-TR-23023-03) for ≤600 volt applications in harsh PWR/BWR environments, in accordance with:

- 10CFR50.49
- IEEE Standards (vary per applicable EQ Qualification Report)
- NRC Regulatory Guide 1.89
- ANSI N45.2
- 10CFR50/Appendix B
- 10CFR21
- NQA-1

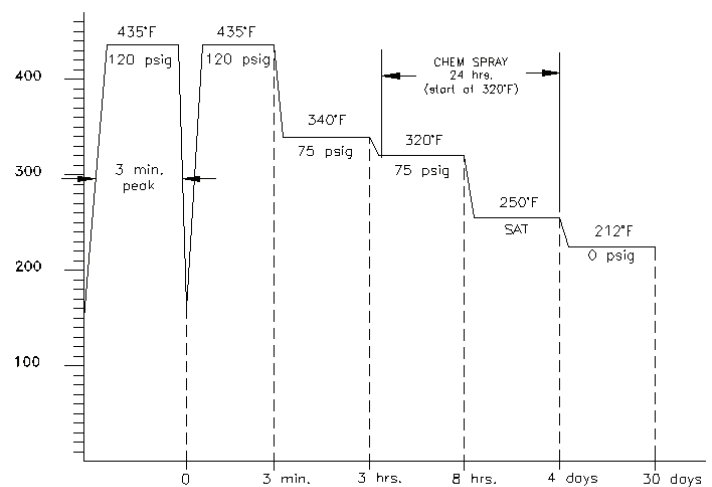

Compact Splice

for PWR/BWR Applications

Installation

Installation of the EGS Compact Splice is a quick and easy process:

1. Strip conductors indicated length per table.
2. Insert conductors into compression connector. Wire insulation O.D. must be smaller than heat shrink I.D.
3. Crimp compression connector with crimp tool.
4. Shrink tubing with heat gun until fully recovered and clear sealant is visible at ends.
5. Refer to EGS Drawing B-N-23023-0001-01 for complete installation instructions. Tool kit P/N: 23023-CT containing the Crimp tool, all dies and GO/NO-GO gauges in a hard side case. This tool kit is required for installation.

How to Order

EGS Part Number	Wire Range (AWG)	Conductor Strip Length (Inches)*	EGS Die for Astro Crimp tool P/N 620175	Insulation Use Range (Inches)
23023-55824**	22 – 18	5/16	23023-03-22/18	0.080 - 0.170
23023-55825	16 – 14	5/16	23023-03-16/14	0.090 - 0.190
23023-55826	12 – 10	3/8	23023-03-12/10	0.120 - 0.240
23023-55845	8	3/8	23023-03-08	0.180 - 0.310

*Nominal

**Qualified for radiation hazard environment only

CONTACT INFORMATION:

18001 Sheldon Road, Middleburg Hts., OH 44130
electricalconnections@curtisswright.com | +1.216.267.3200

Compact Splice

for CANDU Applications

CURTISS - WRIGHT

Nuclear Power Products and Services



Product Description

The EGS Compact Splice is a light-weight, simple solution to single-conductor splicing needs. This splice can be installed, in plant, with little training and the use of a crimp tool and heat gun. The EGS Compact Splice has been CSA qualified for use with both solid conductor and stranded wire.

Qualification Levels

- Qualified life: 40 years at 62.6°C (150°F)
- Radiation: tested to 8.31E7 rads gamma
- LOCA: tested to 171°C (340°F) and 15.2 psig (206.2 kPa)

Qualification Standards

Successfully qualified by test (EGS-TR-23023-03) for ≤600 volt applications in harsh CANDU environments, in accordance with:

- 10CFR50.49
- IEEE 323-1974/83
- IEEE 383-1974
- NRC Regulatory Guide 1.89
- ANSI N45.2
- 10CFR50/Appendix B
- 10CFR21
- NQA-1

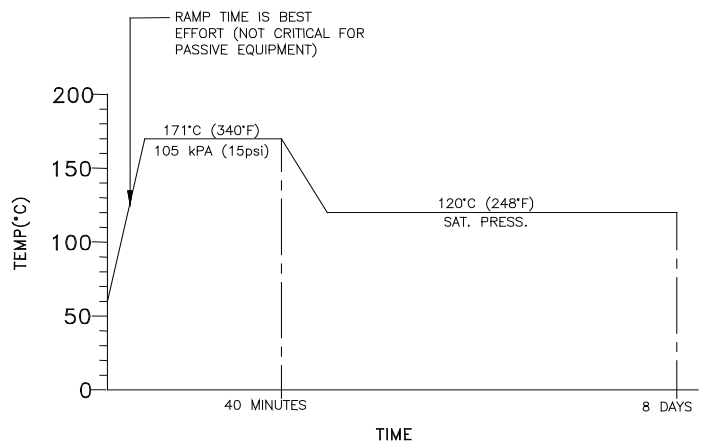

Compact Splice

for CANDU Applications

Installation

Installation of the EGS Compact Splice is a quick and easy process:

1. Strip conductors indicated length per table.
2. Insert conductors into compression connector. Wire insulation O.D. must be smaller than heat shrink I.D.
3. Crimp compression connector with crimp tool.
4. Shrink tubing with heat gun until fully recovered and clear sealant is visible at ends.
5. Refer to EGS Drawing B-N-23023-0001-01 for complete installation instructions. Tool kit P/N: 23023-CT containing the Crimp tool, all dies and GO/NO-GO gauges in a hard side case. This tool kit is required for installation.

How to Order

EGS Part Number	Wire Range (AWG)	Conductor Strip Length (Inches)*	EGS Die for Astro Crimp tool P/N 620175	Insulation Use Range (Inches)
23023-55824**	22 – 18	5/16	23023-03-22/18	0.080 - 0.170
23023-55825	16 – 14	5/16	23023-03-16/14	0.090 - 0.190
23023-55826	12 – 10	3/8	23023-03-12/10	0.120 - 0.240
23023-55845	8	3/8	23023-03-08	0.180 - 0.310

*Nominal

CONTACT INFORMATION:

18001 Sheldon Road, Middleburg Hts., OH 44130
 electricalconnections@curtisswright.com | +1.216.267.3200

Electrical Splicing Tape

for Harsh Environments

**CURTISS -
WRIGHT**

Nuclear Power Products and Services



Product Description

An easy-to-install alternate for electrical splicing.

Applications

- Moisture sealing electrical splices
- Motor lead connections
- Jacket repairs
- End sealing of cables

Design Features

- Self-bonding
- Easy Installation
- In-line, "V", 3-way and parallel
- Crimped or bolted
- 600 volt (LOCA)
- 266°F (130°C) tape rating
- EQ tested
- No maintenance
- Low current leakage
- High insulation resistance
- No adhesives
- No special cleaners
- No special tools
- Flame resistant
- Protects against oils, chemicals, ozone, heat and sunlight

Qualification Levels

600V

- Qualified life: 40 years at 194°F (90°C)
- Radiation: tested to 2E8 rads gamma
- LOCA: tested to 435°F/80 psig (223°C/652.9 kPa), 30-day
- Chemical spray

Medium Voltage

- Qualified life: 40 years at 194°F (90°C)
- Radiation: tested to 5.2E7 rads gamma
- HELB: tested to 412°F (211°C) peak, 6 hour duration

Qualification Standards

Successfully qualified by test for power and control circuits in harsh environments, in accordance with:

- ANSI N45.2
- 10CFR50/Appendix B
- 10CFR50.49
- 10CFR21
- NQA-1
- IEEE Standards (vary per applicable EQ Qualification Report)

Electrical Splicing Tape

for Harsh Environments

Test Report	Application Instruction	Voltage	Insulation	Jacket	Cover
SAIC-TR-399.16-05	SAIC-TR-399.16-02	0-600	Scotch 130C	Bishop 44	N/A
EGS-TR-399.16-16	EGS-TR-399.16-14	0-600	Scotch 130C	Scotch 130C	(Note 1)
EGS-TR-399.16-21	EGS-TR-399.16-22	0-600	Scotch 130C	Scotch 130C	Scotch 69
EGS-TR-399.16-20	SAIC-TR-399.16-11	Medium (Note 2)	Scotch 130C	Bishop 44/Scotch 130C	(Note 1)

Notes:

1. Scotch 69 can be used as an optional covering tape over the jacketing tape to provide additional mechanical protection and will prevent the Scotch 130C tape from adhering to adjacent splices or metallic structures.
2. For stress shielding over all conductors energized at 2000 volts or greater, EGS used Bishop 17 semi-conducting tape and Scotch 24 shielding tape.

How to Order

EGS Harsh Environment Electrical Splicing Tape is ordered by product number.

Example: 399.16 - EPR - 3/4 - 30

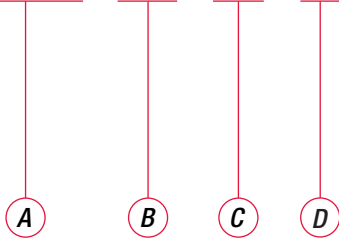

Project Number	Material	Width (inches)	Length (feet)	Description
399.16	EPR	3/4	30	3M Scotch 130C Ethylene Propylene Rubber Insulating and Jacketing Tape
399.16	EPR	1.0	30	
399.16	EPR	1.5	30	
399.16	EPR	2.0	30	
399.16	NEO	3/4	30	Bishop 44 Neoprene Jacketing Tape
399.16	SC	3/4	15	Bishop 17 Semi-Conducting EPR Tape
399.16	CU	1	15	Scotch 24 Copper Braid Tape
399.16	GLS	3/4	66	Scotch 69 Glass Covering Tape

CONTACT INFORMATION:

18001 Sheldon Road, Middleburg Hts., OH 44130
 electricalconnections@curtisswright.com | +1.216.267.3200

Nuclear Power Products and Services

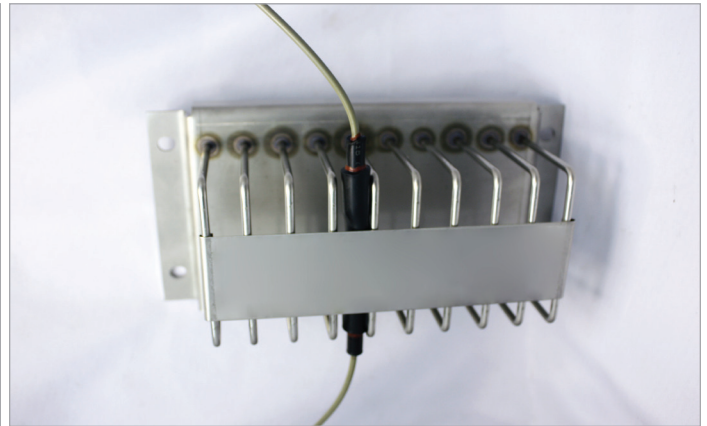

Product Description

A splice rack is a rugged, user-friendly device that organizes multiple splice areas, such as those within electrical enclosures. The rack provides easy splice identification for safety, convenience, and organization.

The EGS Splice Rack is a multi-splice mechanical device consisting of two stainless steel partitions which secure the splices within the same electrical enclosure. The rack utilizes a securing rod which prevents the splices from exiting the channel. Each channel can hold up to four splices.

Design Features

- Easy installation/simple assembly procedures
- Multi-splice capability
- Avoids messy and confusing multiple splice locations
- 304SST
- Custom configurations and mounting footprints available
- No special tools or preassembly required
- No maintenance
- Compatible with ALARA considerations

Qualification Levels

- Seismic: ZPA of 6.0g horizontal and 7.3 ZPA vertical
- Supplied under a quality assurance program in accordance with ANSI N45.2 and 10CFR50, Appendix B

Qualification Standards

Successfully seismically qualified by test in accordance with:

- IEEE 344-1987

How to Order

The Splice Rack is ordered by part number:

- **23047-117** – Single Row Multiple Splice Rack

Note: The Splice Rack is provided with a standard mounting configuration but may be modified if required.

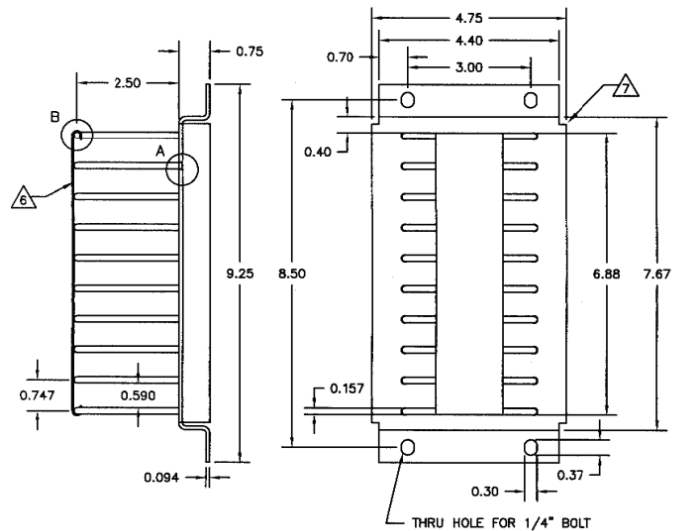

CONTACT INFORMATION:

18001 Sheldon Road, Middleburg Hts., OH 44130
 electricalconnections@curtisswright.com | +1.216.267.3200

EGS Thread Sealant

(P-1)

**CURTISS -
WRIGHT**

Nuclear Power Products and Services



Product Description

P-1 is a universally applicable thread sealant for use on many different materials, products, and size ranges. The sealant is an easy to apply graphite paste.

Product Features

- Qualified for use on 1/4" to 1-1/2" NPT joint
- Applicable to stainless steel, brass, galvanized steel, and carbon steel
- Seals both new and used threads
- Easy application
- No curing required

Qualification Levels

- Acceptable for service temperatures up to 850°F (454°C)
- Radiation resistant
- Seismic: 6.0g ZPA
- LOCA: tested to 412°F (211°C), 88 psig (708.1 kPa), 100% R.H, and chemical spray

Qualification Standards

Successfully qualified by test in accordance with:

- IEEE 323-1974
- IEEE 344-1975
- 10CFR50.49
- ANSI N45.2
- 10CFR50/Appendix B

How to Order

EGS Thread Sealant paste is supplied in standard 4 oz. containers and is ordered by Part Number: P-1.

CONTACT INFORMATION:

18001 Sheldon Road, Middleburg Hts., OH 44130
electricalconnections@curtisswright.com | +1.216.267.3200

Conformal Coating (PECC)



Nuclear Power Products and Services



Product Description

PECC is a transparent resin solution that offers excellent dielectric properties, moisture resistance and thermal shock properties. PECC's primary usage is as a coating applied to terminal blocks and other electrical terminations. PECC eliminates excessive leakage current during postulated accident conditions and minimizes loss of insulation resistance.

Applications

PECC should be applied to a clean dry surface. Apply PECC with a non-conductive, soft bristled brush. Application instructions are supplied upon request.

Product Features

- One-part compound – no mixing or measuring
- Easy application
- May be applied to energized circuits
- Suitable for most qualified non-polystyrene terminal block materials
- Curable at room temperature
- Tack-free in one hour
- Easily removed for later access to circuits

Qualification Levels

- Qualified life: 40 years at 194°F (90°C)
- Radiation: tested to 2E7 rads gamma
- Seismic: 6.0g ZPA
- Accident tested to 355°F (179°C), 30 psig (308.2 kPa), and 100% R.H.

Qualification Standards

Successfully qualified by test in accordance with:

- IEEE 323-1983
- IEEE 344-1975
- 10CFR50.49
- ANSI N45.2
- 10CFR50/Appendix B
- MIL-I-46058C qualified
- IPC-CC-830A qualified

How to Order

PECC is available in 4-oz. containers and ordered as Part Number: PECC.

CONTACT INFORMATION:

18001 Sheldon Road, Middleburg Hts., OH 44130
electricalconnections@curtisswright.com | +1.216.267.3200

Contact Information

CGD/EQ Services

18001 Sheldon Road,
Middleburg Hts., OH 44130
U.S.A.

P: +1.216.267.3200

E: electricalconnections@curtisswright.com

www.cwnuclear.com

***CURTISS -
WRIGHT***

Headquarters: 2950 E Birch Street, Brea, CA 92821, U.S.A. | www.cwnuclear.com

Facilities: Berwick, PA | Cincinnati, OH | Danbury, CT | Frederick, MD | Hutchinson, MN | Idaho Falls, ID | Middleburg Heights, OH | Newmarket, Ontario, Canada

While this information is presented in good faith and believed to be accurate, Curtiss-Wright does not guarantee satisfactory results from reliance on such information. Nothing contained herein is to be construed as a warranty or guarantee, expressed or implied, regarding the performance, merchantability, fitness or any other matter with respect to the products, nor as a recommendation to use any product or process in conflict with any patent. Curtiss-Wright reserves the right, without notice, to alter or improve the designs or specifications of the products described herein.