

Nuclear Power Products and Services

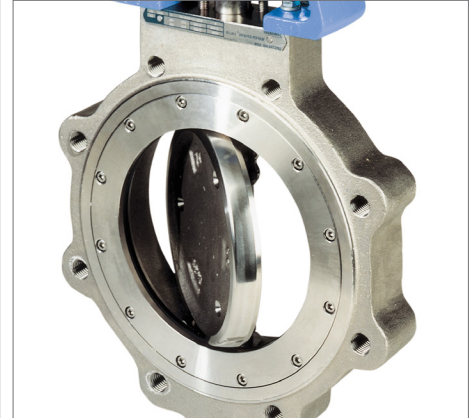

### Obsolete 8000 Series Replacement

The Jamesbury 8000 Series High Performance Butterfly Valve (HPBV) has operated in commercial, Safety-Related, and ASME Code Section III nuclear applications for over three decades. Over this period, Jamesbury has made a variety of improvements to the valve design in an effort to reduce maintenance and improve component reliability.

Through these enhancements, the Jamesbury 815/830 series HPBV was born as a replacement for the original 8000 series valve, which became obsolete in the early 1990s. This butterfly valve incorporates new design features that improve reliability and performance and reduce overall operating costs. To eliminate unnecessary engineering costs, the 815/830 series can be made available as a drop-in-replacement for 8000 series installations.

### Enhanced Seal Design

A significant improvement in the 815/830 series valve compared to the 8000 series valve is the flexible lip seal design. This field-proven, single piece seat is more robust, providing Class VI shut-off in both directions. Additional benefits of the seat include:

- Increased flexibility of seat without deformation
- Improved resistance to cold flow or compression set
- Maximum utilization of system pressure to assist shut-off
- Longer service life with reduced maintenance

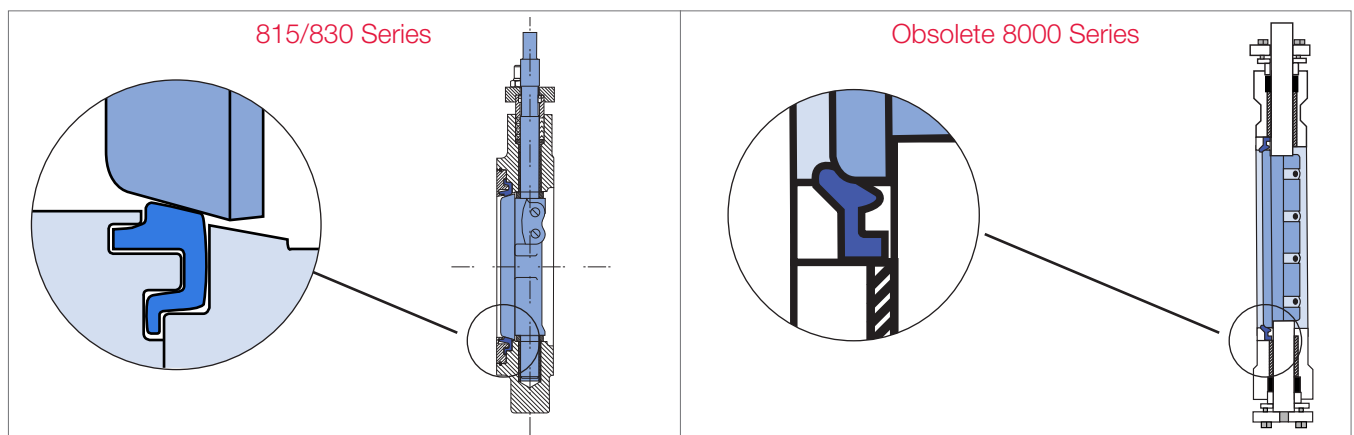

The 815/830 series design includes a more robust flexible lip seal that provides Class VI bidirectional shut-off.

# Jamesbury

## Obsolete 8000 Series Replacement

### Consistent Operating Torque

Unlike the 8000 series, the 815/830 series includes thrust bearings. In the 8000 series design the net force acting on the shaft makes it susceptible to disc misalignment. The addition of the thrust bearings in the 815/830 series allows for precise disc alignment. This leads to an overall improvement in operating torque.

### 815 vs 8000 Series Torque Values (FT-LBs @ 200PSID)

ANSI Class 150, Shaft Down Stream, TFE Filled Seat

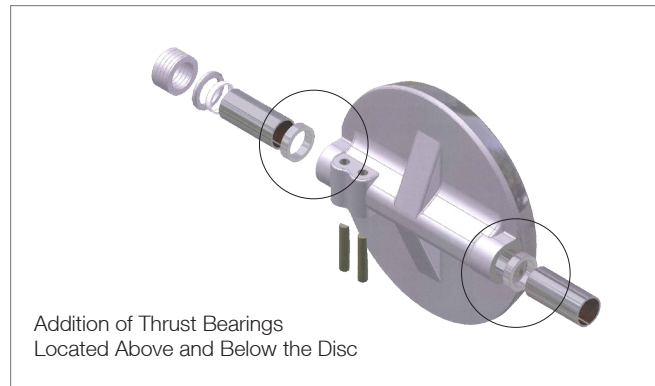

Valve Size	3"	4"	6"	8"	10"	12"	14"	16"	18"	20"	24"	30"	36"	42"	48"	54"	60"
8000 Series (approximate)	33	49	120	190	300	400	600	880	1100	1500	2000	3200	4650	5900	7900	16800	24500
815 Series	27	39	83	142	202	287	505	646	844	1140	1758	2940	4860	8060	12840	17900	26040

### Ease of Maintenance

Unlike most HPBVs where removing the shaft and disc is required, the seat retention of the 815/830 series HPBV provides for easy seat replacement. The seat can be replaced by simply removing the body inserts and inserting the new seat, which is self-aligning.

### Obsolete 8000 Series Support

Although the Jamesbury 8000 Series HPBV is obsolete, a "soft" goods repair kit is available for this valve design that includes the seat, shaft seals, and insert pins. Spare parts for the "hard" components are extremely limited and must be assessed on a case by case basis. It is highly recommended that a plant upgrade to the 815/830 design if they are in need of "hard" components.

### Complete Valve and Actuator Package

The 815/830 series butterfly valve coupled with either a Bettis pneumatic or Bernard Controls motor/electric actuator provides for a complete solution to your obsolete 8000 series valve and actuator assembly. Our team of nuclear experienced application engineers can help select the best product for your plant systems. Our capabilities include sizing, selecting, assessing torque values, and evaluating the form, fit, and function of your replacement valve and actuator assembly, which will significantly reduce the amount of engineering design work by plant personnel.



#### CONTACT INFORMATION:

2950 Birch Street, Brea, CA 92821  
enertech@curtisswright.com | +1.714.528.2301