



Enertech Snubbers

Dynamic Restraint for Large Equipment, Components, and Vessels

Enertech Nuclear Snubbers

for dynamic restraint of large equipment, components, and vessels

40 Year Life

Enertech, formerly Paul-Munroe Hydraulics, is a product and service brand of Curtiss-Wright Nuclear. Since 1970, Curtiss-Wright Nuclear has specialized in design and manufacturing of dynamic restraints (snubbers) for the commercial nuclear power industry. We have supplied over 100 nuclear reactors with critical, load-bearing devices used for seismic support of steam generators, reactor coolant pumps, torus rings, main steam piping and other large components. The snubber's exclusive 40 year seal life design employs Tefzel® material for high resistance to radiation and thermal aging for inside containment building use. This field-proven technology precludes the need to remove and service snubber seals for 40 years, resulting in low cost of ownership.

Load Capacities and Options

The large equipment snubber ranges from 50,000 and 2,000,000 pound capacity and may be ordered with extension, wall brackets, clevis pins and in custom stroke lengths. This specialized snubber design is for high dynamic load requirements and is produced in accordance with ASME Section III, NPT Stamp and NQA-1. RCC-M and DIN standards have also been used extensively in snubber manufacturing.

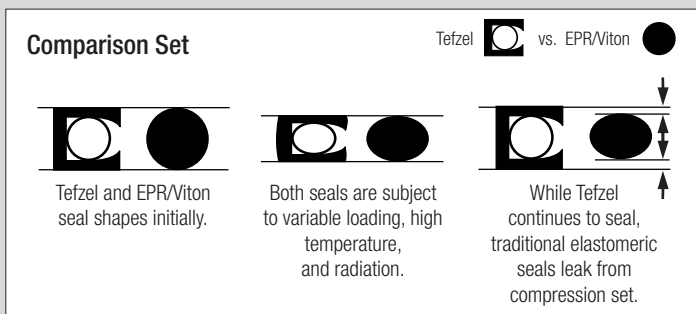
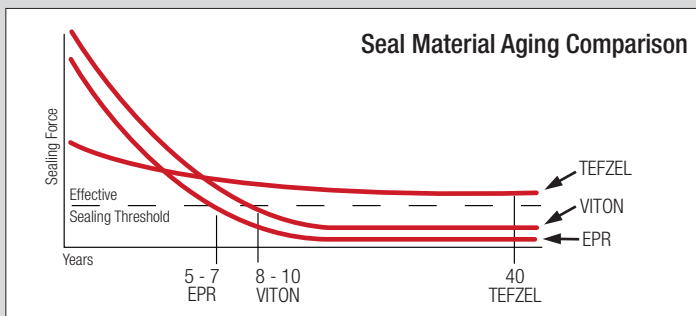
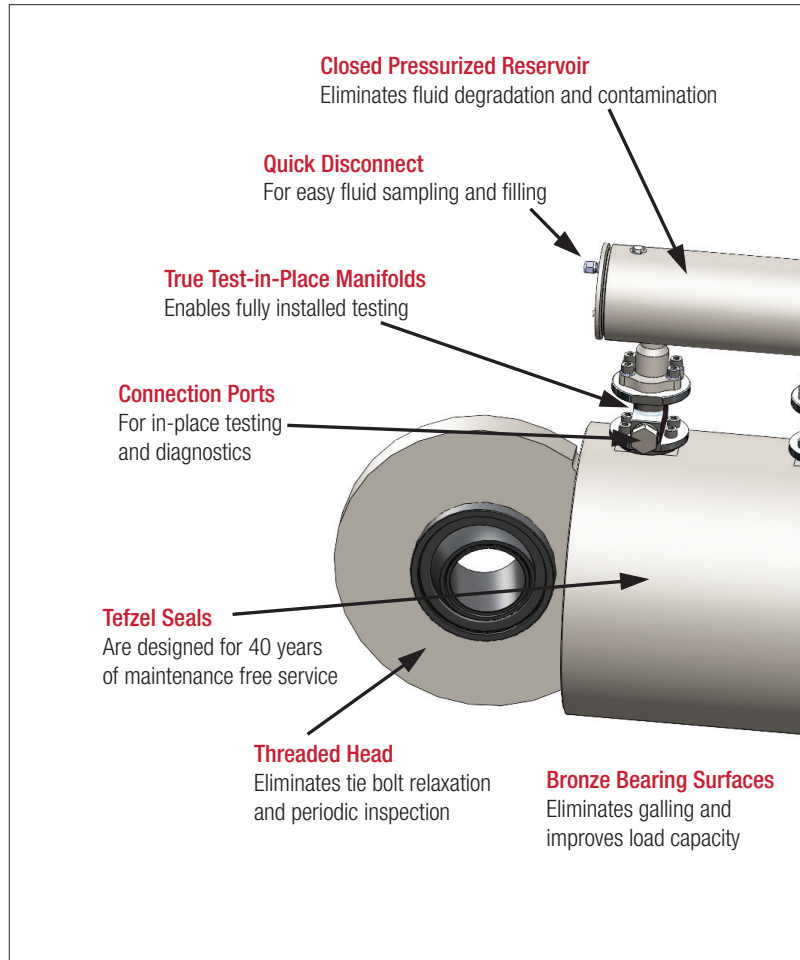
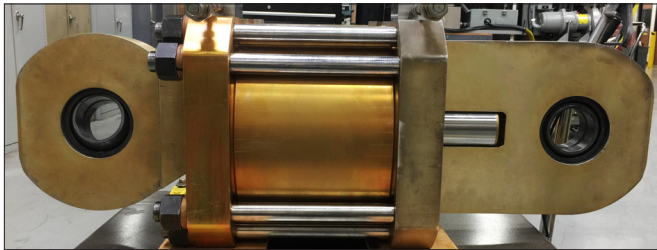

Maintenance Free Seals

Tefzel seals are environmentally qualified for a 40 year design life and require no maintenance. They have been supplied to over 100 nuclear power plants worldwide, and have established a 30 year history of proven reliability.

Tefzel seals provide:

- High resistance to radiation and elevated temperatures
- Spring loaded to eliminate compression set effect
- Low friction and breakaway force

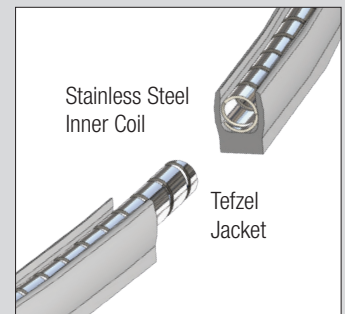

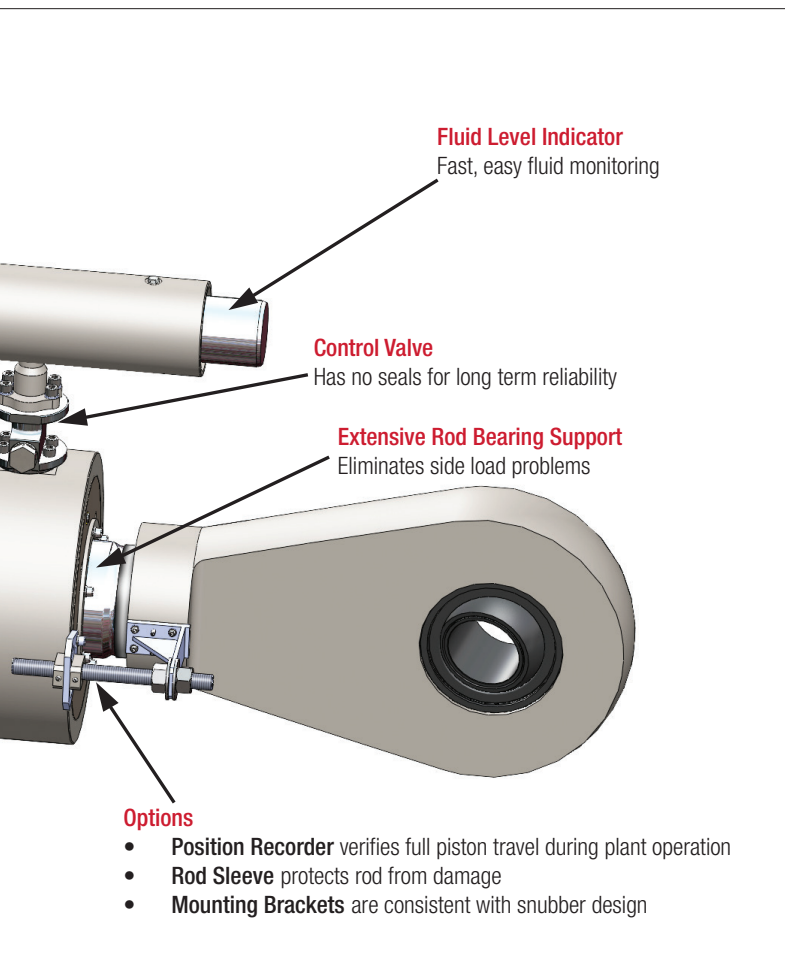

Design Qualification

Curtiss-Wright Nuclear's snubber qualification program is one of the industry's most stringent design validation efforts for large dynamic restraints. When testing for dynamic load response, a major commercial airplane manufacturer was contracted to apply high loads to the snubber on a massive test fixture normally used for aviation structure fatigue and weak link evaluation. These tests applied up to 2,000,000 pound axial load. The snubber design successfully passed this demanding examination, confirming instantaneous response of our control valves and high spring constant (stiffness) during accident loading conditions. Curtiss-Wright Nuclear has also worked closely with a leading supplier of spherical ball bushings used at structural connection points to assure high spring constant is maintained throughout the snubber component design.

Legacy Snubber Brands

Curtiss-Wright Nuclear provides exclusive OEM spare parts and field services for our legacy snubber brands including Paul-Munroe, Anker-Holth, McDowell-Wellman and E-Systems®. This comprehensive support includes engineering services for re-rating and design change needs.



All Metal, Self-Flushing Control Valve

The cartridge-style snubber control valve provides positive lock-up activation in the event of rapid snubber movement in compression and tension modes, restraining seismic and pipe whip energies. Normal plant thermal movement is permitted. All metal construction of the snubber control valve is dirt tolerant due to a self cleaning flow path. To further eliminate need for snubber handling or routine maintenance, no elastomers are employed in the control valve design or in its connection to the main cylinder. A sealed reservoir may also be specified to prevent potential for ingress of airborne moisture.

Enertech's control valve features:

- Rugged stainless steel construction
- Highly reliable cartridge valve requiring no seals
- Tamper-proof, factory set lock-up and bleed rates
- Continuous flushing action prevents clogged orifices and sticking valves
- Bleed orifice in line with flow

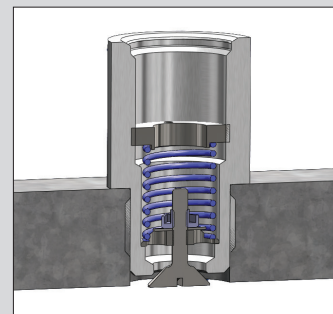

Surveillance Testing

For convenient surveillance testing, Curtiss-Wright Nuclear has developed a flexible program for routine inspection of large snubber seal integrity, control valve activation, and bleed rate performance with TESTAN II. The compact TESTAN II portable test console may be used in a clean room near the reactor building or brought into containment for in-situ, True Test-in-Place inspection of the snubber. The two control valves may be temporarily removed and transported to the clean room or remain engaged to the snubber during test.

TESTAN & TTIP Technology

True Test-in-Place (TTIP) technology consists of temporarily isolating the control valves from the snubber body and testing for lock-up, bleed rate and seal integrity. This is achieved by installing permanent TTIP manifolds between the control valve and the snubber. TTIP then utilizes the portable TESTAN II as an external flow and pressurization source (10,000 PSI pressure capability) to perform snubber operation verification.

Each large bore snubber can be equipped with patented TTIP manifolds which allow full functional testing with minimum setup and test time, and without having to remove pins or valves. Note these advantages:

- In-place operability verification tests include activation (lock-up), release rate (bleed) and seal integrity
- Traceability to full function bench test
- Full compliance with O&M 4 and Section XI in-service inspection
- Reduced personnel radiation exposure
- Test “as found” condition without having to remove clevis pins or valves
- Full compatibility with EnerTech's TESTAN portable test equipment

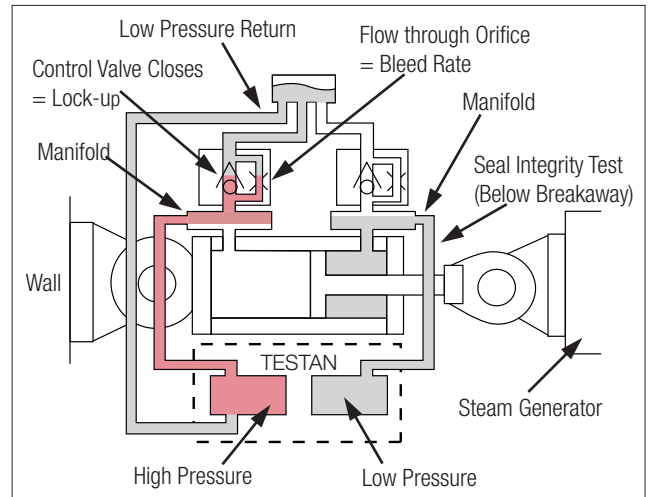

Contact Information

EnerTech

2950 E Birch Street, Brea, CA 92821, U.S.A.

P: +1.714.528.2301

F: +1.714.528.0128

E: enertech@curtisswright.com

**CURTISS -
WRIGHT**

Curtiss-Wright Nuclear Headquarters: 2950 E Birch Street, Brea, CA 92821, U.S.A. | www.cwnuclear.com

Facilities: Berwick, PA | Cincinnati, OH | Clearwater, FL | Cromwell, CT | Danbury, CT | Freeport, PA | Hutchinson, MN | Huntsville, AL | Idaho Falls, ID | Middleburg Heights, OH | Mooresville, NC | Two Rivers, WI | Newmarket, Ontario, Canada

While this information is presented in good faith and believed to be accurate, Curtiss-Wright does not guarantee satisfactory results from reliance on such information. Nothing contained herein is to be construed as a warranty or guarantee, expressed or implied, regarding the performance, merchantability, fitness or any other matter with respect to the products, nor as a recommendation to use any product or process in conflict with any patent. Curtiss-Wright reserves the right, without notice, to alter or improve the designs or specifications of the products described herein.