

Nuclear Products and Services

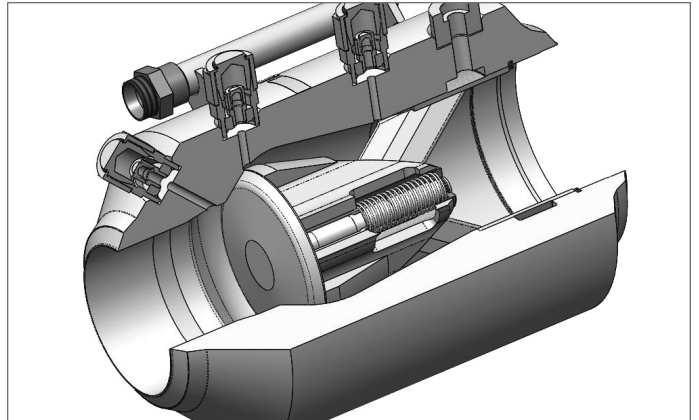
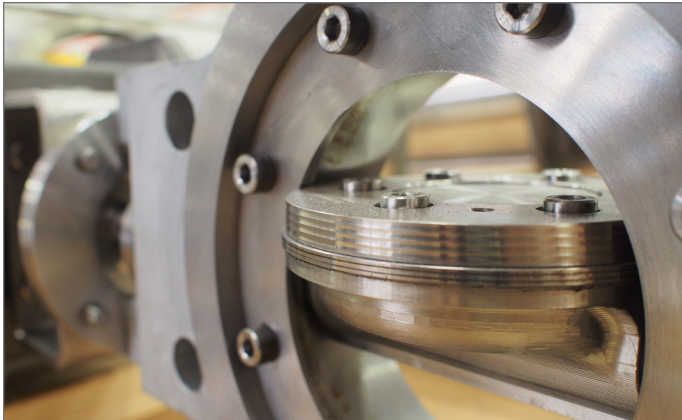

Curtiss-Wright offers a comprehensive range of products and services to the commercial nuclear power industry through its legacy brand, Enertech. The Enertech history in the nuclear power industry began in 1967 with the development of the first nuclear qualified hydraulic large bore snubber. Today, Curtiss-Wright provides Enertech products and services to the global nuclear power industry including commercial nuclear power plants, NSSS suppliers, A&E's, and the U.S. Department of Energy.

Curtiss-Wright understands the importance of supply chain stability and has established strategic relationships with companies whose products and services are vital to successfully operating nuclear power plants. Several of our OEM partners maintain their QA programs, while others rely on Curtiss-Wright's unique, innovative, and integrated QA process to provide safety-related and ASME Section III parts.

As an engineering, manufacturing, distribution, and service company, we are dedicated to providing solutions to meet the unique requirements of the nuclear power industry. Curtiss-Wright provides integrated system solutions that include advanced valves, actuators, instrumentation, snubbers, diagnostic and test equipment, qualification and dedication services, outage support services, equipment repair, and field service.

Whether it's solving chronic component related problems, obsolescence challenges, maintaining and upgrading installed equipment, assisting with power uprates and plant life extensions, or supporting new reactor construction, we have solutions to maximize performance.

Valves

AMOT

- 3-Way Thermostatic Valves
- Fuel Gas Shut-Off Valves

BIF

- High Performance Butterfly Valves

Circle Seal

- Excess Flow Check Valves
- Poppets & Pressure Regulators

Farris

- Pressure Relief Valves
- Spring Loaded and Pilot Operated

IMO

- 3-Screw Pumps
- Aftermarket Support

ITT Engineered Valves

- Dia-Flo® Diaphragm Valves
- Cam-Tite® Ball Valves

Valmet-Jamesbury

- High Performance Butterfly Valves
- Soft-Seated Ball Valves
- Metal-Seated Ball Valves

Marotta

- Pressure Relief Valves
- Custom-Designed Solenoid Valves
- Excess Flow Check Valves

NozzleCheck

- Axial Flow Check Valves
- Non-Slam Operation
- Eliminates Water Hammer Induced Damage

PermaSeat

- Triple-Offset, Metal Seated Butterfly Valves
- Large Diameter Butterfly Valves
- High Performance Butterfly Valves

Ringo Valves

- Butterfly, Gate, Globe, Check, and Control Valves
- Custom Designed Valves

Actuation

Bettis

- Quarter-Turn Pneumatic Actuators
- IEEE Qualified
- Aftermarket Support

Enertech Electro-Hydraulic Operator (EHO)

- Modulating, Rotary, Linear Actuators
- IEEE Qualified
- Custom Designed Systems

QTRCO

- Quarter-Turn Pneumatic Actuators
- Premium Materials of Construction
- Custom Designed Solutions

Instrumentation & Condition Monitoring

BIF

- Venturi Flow Meters

ITT Conoflow

- Air Filter Regulators
- I/P Transducers
- Positioners
- IEEE Qualified

Snubbers

Enertech

- Large Bore Equipment Snubbers
- True Test-In-Place Manifolds

Nuclear Services

On-Site, Outage Support, and Engineering Services

- Upgrades and Modifications
- Troubleshooting
- Repair, Refurbishment, Rebuilding
- ASME Code Design/Reconciliation
- Seismic Analysis
- Commercial Grade Dedication
- Application Engineering Support
- Obsolescence Solutions
- 24 Hour Technical Support



Enertech Hydraulic Operator (EHO) Actuator



Ringo Gate and Check Valves



Butterfly Valves on Bettis Pneumatic Actuators

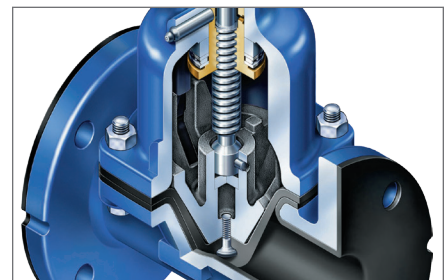

ITT Diaphragm Valve

CONTACT INFORMATION:

2950 E Birch Street, Brea, CA 92821 USA
enertech@curtisswright.com | +1.714.528.2301